

6501

**Full Rise Scissor Lift Surface Mounted
Lifting Capacity: 3000 KG**

**INSTALLATION, OPERATION
AND MAINTENANCE MANUAL**



Read this entire manual carefully and completely before installation or operation of the lift.

INDEX

1. Important safety instructions.....	3~5
1.1 Important notices	
1.2 Qualified personnel	
1.3 Danger notices	
1.4 Warning signs	
1.5 Sound level	
1.6 Training	
2. Overview of the lift.....	5~6
2.1 General descriptions	
2.2 Technical data	
2.3 Construction of the lift	
3. Installation instructions.....	6~10
3.1 Preparations before installation	
3.1.1 Tools and equipments needed	
3.1.2 A list for parts checking	
3.1.3 Ground conditions	
3.2 Precautions for installation	
3.3 Installation	
3.4 Items to be checked after installation	
4. Operation instructions.....	10~12
4.1 Precautions	
4.2 Descriptions of control box	
4.3 Flow chart for operation	
4.4 Operating instructions	
4.5 Emergency lowering in case of no power	
5. Trouble shooting.....	13
6. Maintenance.....	14
7. Annex.....	15~30
Annex1,Packing list of the whole lift	
Annex2,Overall diagram	
Annex3,Diagram for ground fixing	
Annex4,Diagram for oil hose connection	
Annex 5,Hydraulic working system	
Annex6,Wiring diagram	
Annex7,Diagram for air source connection	
Annex8,Separate diagrams for the lift	
Annex9,Spare parts list	
Annex10,Size and weight requirements on vehicles	

1. Important safety instructions

1.1 Important notices

Ever-Eternal will offer one-year's quality warranty for the whole machine , during which any quality problem will be properly solved to the user's satisfaction. However, we will not take any responsibility for whatever bad consequence resulted from improper installation and operation, overload running or unqualified ground condition.

This model is specially designed for lifting motor vehicles that weighs within its outmost lifting capacity. Users are not allowed to use it for any other purposes. Otherwise, we, as well as our sales agency, will not bear any responsibility for accidents or damages of the lift.

Make sure to pay careful attention to the label of the lifting capacity attached on the lift and never try to lift cars with its weight beyond.

Read this manual carefully before operating the machine so as to avoid economic loss or personnel casualty incurred by wrong operation.

Without our professional advice, users are not permitted to make any modification to the control unit or whatever mechanical unit.

1.2 Qualified personnel

1.2.1 Only these qualified staff, who have been properly trained, can operate the lift.

1.2.2 Electrical connection must be done by a competent electrician.

1.2.3 People who are not concerned are not allowed in the lifting area.

1.3 Danger notices

1.3.1 Do not install the lift on any asphalt surface.

1.3.2 Read and understand all safety warnings before operating the lift.

1.3.3 Do not leave the controls while the lift is still in motion.

1.3.4 Keep hands and feet away from any moving parts. Keep feet clear of the lift when lowering.

1.3.5 Only these properly trained personnel can operate the lift.

1.3.6 Do not wear unfit clothes such as large clothes with flounces, tires, etc, which could be caught by moving parts of the lift.

1.3.7 To prevent evitable incidents, surrounding areas of the lift must be tidy and with nothing unconcerned.

1.3.8 The lift is simply designed to lift the entire body of vehicles, with its maximum weight within the lifting capacity.

1.3.9 Always insure the safety latches are engaged before any attempt to work near or under the vehicle. Never remove safety related components from the lift. Do not use if safety related components are damaged or missing.

1.3.10 Do not rock the vehicle while on the lift or remove any heavy component from vehicle that may cause excessive weight shift.

1.3.11 Check at any time the parts of the lift to ensure the agility of moving parts and the performance of synchronization. Ensure regular maintenance and if anything abnormal occurs, stop using the lift immediately and contact our dealers for help.

1.3.12 Lower the lift to its lowest position and do remember to cut off the power source when service finishes.

1.3.13 Do not modify any parts of the lift without manufacturer's advice.

1.3.14 If the lift is going to be left unused for a long time, users are required to:

- a. Disconnect the power source;
- b. Empty the oil tank;
- c. Lubricate the moving parts with hydraulic oil.

Attention: For environment protection, please dispose the disused oil in a proper way.

1.4 Warning signs

All safety warning labels are clearly depicted on the lift to ensure that the operator is aware of and avoids the dangers of using the lift in an incorrect manner. The labels must be kept clean and they have to be replaced if detached or damaged. Please read carefully the meaning of each label and memorise them for future operation.

CAUTION		WARNING		
				
Never stand, work or be under the lift while it is being operated.	The operator should not stand too close to the lift but in a safe position away from moving parts.	When the lift is lowered, no auxiliary stand or other blocking objects should be near the lift.	Do not shake or push the vehicle whilst it is on the lift.	Only trained technicians are permitted to operate this lift.
				
Ensure feet and other parts of your body are well clear of the lift when it is being lowered or when lifting.	Never try to lift or lower only 1 platform.	Do not change, tamper or interfere with the safety mechanisms of this lift.	Ensure that the lifting weight of the vehicle is balanced on both platforms to avoid tilting or sliding.	
				
Always keep the lifts pit clean and clear of any objects or contaminants.	Please read and study the operation manual carefully before operating this lift.	Keep the vehicle parallel with the platform lifts at all times.	High voltage in control box, take extreme caution here.	

1.5 Sound Level

The sound emitted from the lift should not exceed 75DB. For the sake of your health, we suggest putting a noise detector in your working area.

1.6 Training

Only these qualified people, who have been properly trained, can operate the lift. We are quite willing to provide professional training for the users when necessary.

2. Overview of the lift

2.1 General descriptions

This full rise scissor lift is of pretty lower profile when at its lowest position. Its four cylinder structure makes the lowest 110mm clearance from ground come true. Currently this model is designed with two different leveling systems-auto leveling and manual leveling. For it is specially designed for surface mounting, users could have it installed with great convenience. Its platform extension deign may not only be used as a ramp, but also can serve as an extended part of the platform for much longer vehicles. Besides, designs like, 24V working voltage of control box and limit switch, alarming buzzer, pneumatic safety lock, anti-surge valves, etc have fully considered your personal security.

Safety structure:

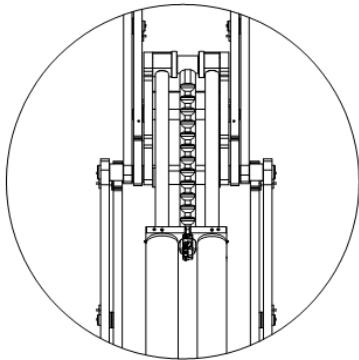

2.2 Technical data

Model	Lifting capacity	Lifting time	Lifting height	Electrical requirement	
6501	3000kg	50 Sec	1850mm	220V/240V, Single Phase	380V/415V, Three Phase

2.3 Construction of the lift

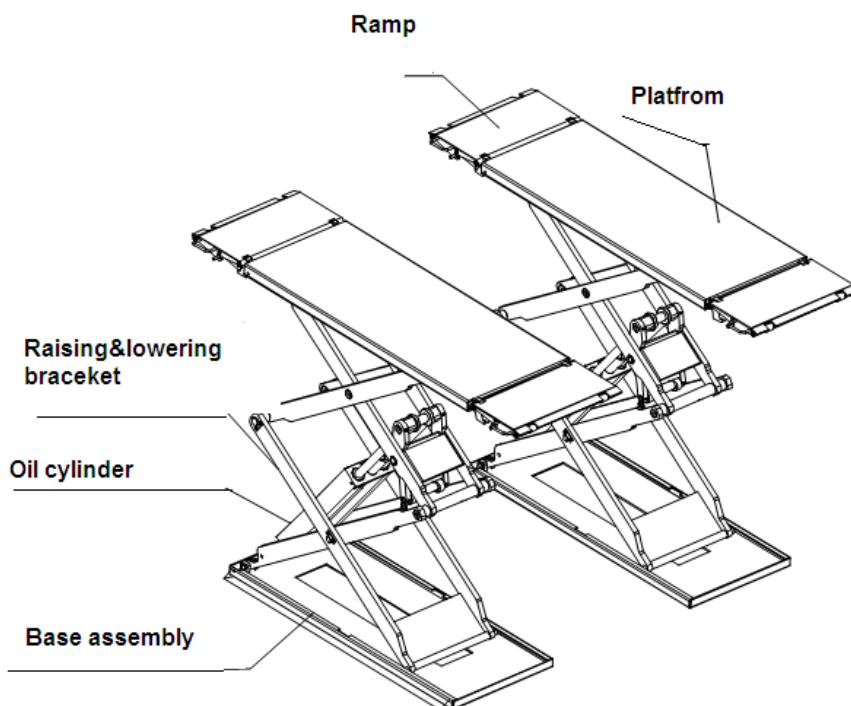

3. Installation instructions

3.1 Preparations before installation

3.1.1 Tools and equipments needed

- √ Electrical drill
- √ Open wrenches
- √ Screw drivers
- √ Adjustable spanner

3.1.2 List for parts checking ---Annex 1 (Packing list)

Unfold the package and check if any parts missed as per Annex 1. Do not hesitate to contact us in case any parts missed, but if you do not contact us and insist installing upon the lack of some parts, Ever-eternal as well as our dealers will not bear any responsibility for this and will charge for any parts subsequently demanded by the buyer.

3.1.3 Ground conditions

The lift should be fixed on a smooth and solid concrete ground with its strength more than 3000psi, tolerance of flatness less than 5mm and minimum thickness of 200mm. In addition, newly built concrete ground must undergo more than 28days' cure and reinforcement.

3.2 Precautions for installation

- 3.2.2 Joints of oil hose must be firmly connected in order to avoid leakage.
- 3.2.3 All bolts should be firmly screwed up.
- 3.2.4 Do not place any vehicle on the lift in the case of trial running.

3.3 Installation

Step1, Connect oil hose (This step is extremely important, so do refer to the diagram for of oil hose connection in **Annex4** and understand the following instructions before proceeding)

Firstly, make sure there is nothing obstructed or dirty left in the hose.

Secondly, installers have to distinguish where the chief oil hose to be connected by referring to the below two pictures and have the chief hose connected.

Thirdly, see the left picture followed by, two branches of the chief oil hose are going to be respectively connected to the tie-ins for chief oil hose reserved on the hydraulic block and the other scissor. Similarly, branches of the other two leveling hoses are going to be connected to the tie-ins reserved for leveling hoses.

Finally, check if all connections are tightened.

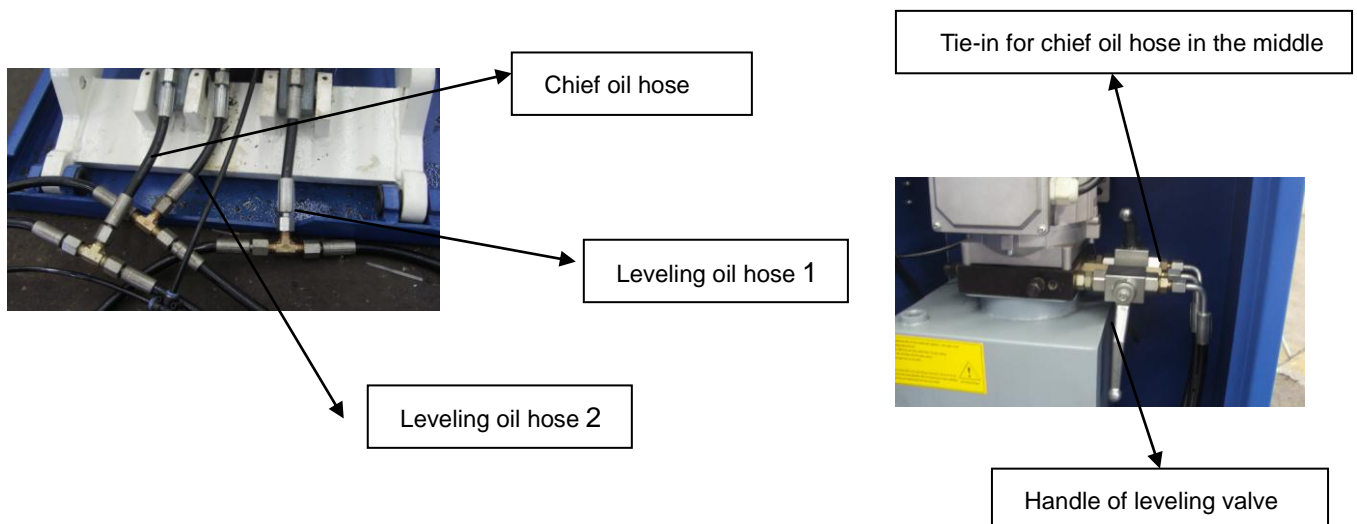

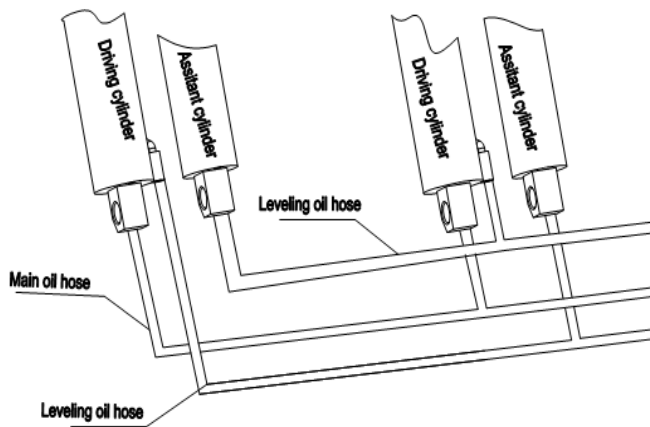

Step2, Connect the wiring and air system

Connect exterior wires as per the wiring diagram, with the black for phase wire, the blue for null wire, and the green -yellow for grounded conductor. Connect the compressed air supply to the air inlet of the pump and then have the air hose(Φ10×Φ7mm, prepared by the user) of the pneumatic safety lock connected to the air outlet of the pump.

Attention : Pressure of the air supply should be among 0.6-0.8kg/cm².



Step3, Fill with hydraulic oil

Pour into the oil tank with 16liters of anti-grinding oil. Level of the oil shall be 10mm to 40mm away from the top of the tank.(users can measure it by the feeler attached on the lid)

Step4, Leveling

Attention : Level the platforms before connecting height limit switch because if not, platforms can not rise to the highest position. Before leveling, make sure the oil hoses are correctly connected. Otherwise, oil cylinders may not work synchronously or could be damaged. In addition, operators need to know clear which leveling valve controls which platform. This could be judged by the way that the oil hose was connected or by trial raising or lowering.

Manual leveling

Open one of the leveling valves and press the UP button to supplement oil to the oil hose connected. Close the valve to stop adding oil. In normal working condition, both leveling valves are closed. If both valves are open, two platforms of the lift can still rise but will not move upwards synchronously.

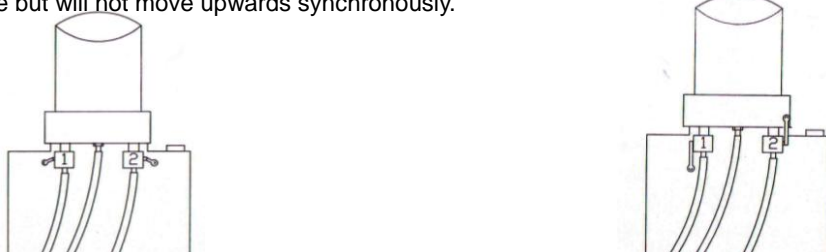

A. Both valves open

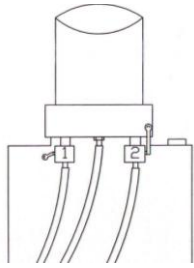

B. Both valves closed : Normal working

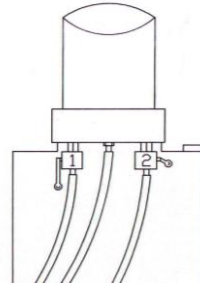

C

D.

One valve open, the other closed: leveling condition

- A1.** Open both leveling valves and press the UP button to have both platforms raised to the highest positions. Repeat this step for two or three times. (Take care that this step could be time consuming, because there's air in the cylinders and no load on the platforms.)
- A2.** Close both leveling valves as per drawing B. Press the UP button to see if both platforms rise synchronously. (Normally, till now the platforms may not rise synchronously.)
- A3.** If not work synchronously, one platform may rise faster than the other. Users should first judge which leveling valve controls which platform and then open the valve that controls the slower-rising platform to supplement oil into its oil hose. Press the UP button to make both platforms rise to the same height. (The other valve here must be closed.)
- A4.** Close both leveling valves. Press DOWN I button to have both platforms lowered to the lowest position.
- A5.** In case they do not lower synchronously, open the valve that controls the slower-lowering platform and press DWON I button to have them lowered to the lowest position and then close the leveling valve. If the lift is equipped with a height limit switch, press DOWN II button when platforms stop lowering at a height of 500mm from the ground.
- A6.** After both leveling valves having been closed, press the UP button to check if both platforms rise synchronously.
- A7.** Repeat doing step A 5 and stepA 6 until synchronization achieved.

Step 5, Connect the limit switch

Connect the wires reserved for limit switch and fix its protection cover with screws.



3.4 Items to be checked after installation.

S/N	Check items	YES	NO
1	Are two platforms adjusted with the same level?		
2	Are oil hose tightly connected?		
3	Are all electric connections correct?		
4	Are valves of the pump unit oil tight?		

4. Operation instructions

4.1 Precautions

- 4.1.1 Check all the joints of oil hose. Only when there is no leakage, the lift can start work.
- 4.1.2 The lift, if its safety device malfunctions, shall not be used.
- 4.1.3 The machine shall not lift or lower an automobile if its center of gravity is not positioned midway of the rising platforms. Otherwise, Ever-Eternal as well as our dealers will not bear any responsibility for any consequence resulted thereby.
- 4.1.4 Operators and other personnel concerned should stand in a safety area during lifting and lowering process.
- 4.1.5 When platforms being raised to the desired height, switch off the power at once to prevent any wrong operation done by unconcerned people.
- 4.1.6. Make sure the safety lock of the lift is engaged before start working under the vehicle and no people under the vehicle during lifting and lowering process.

4.2 Descriptions of control box

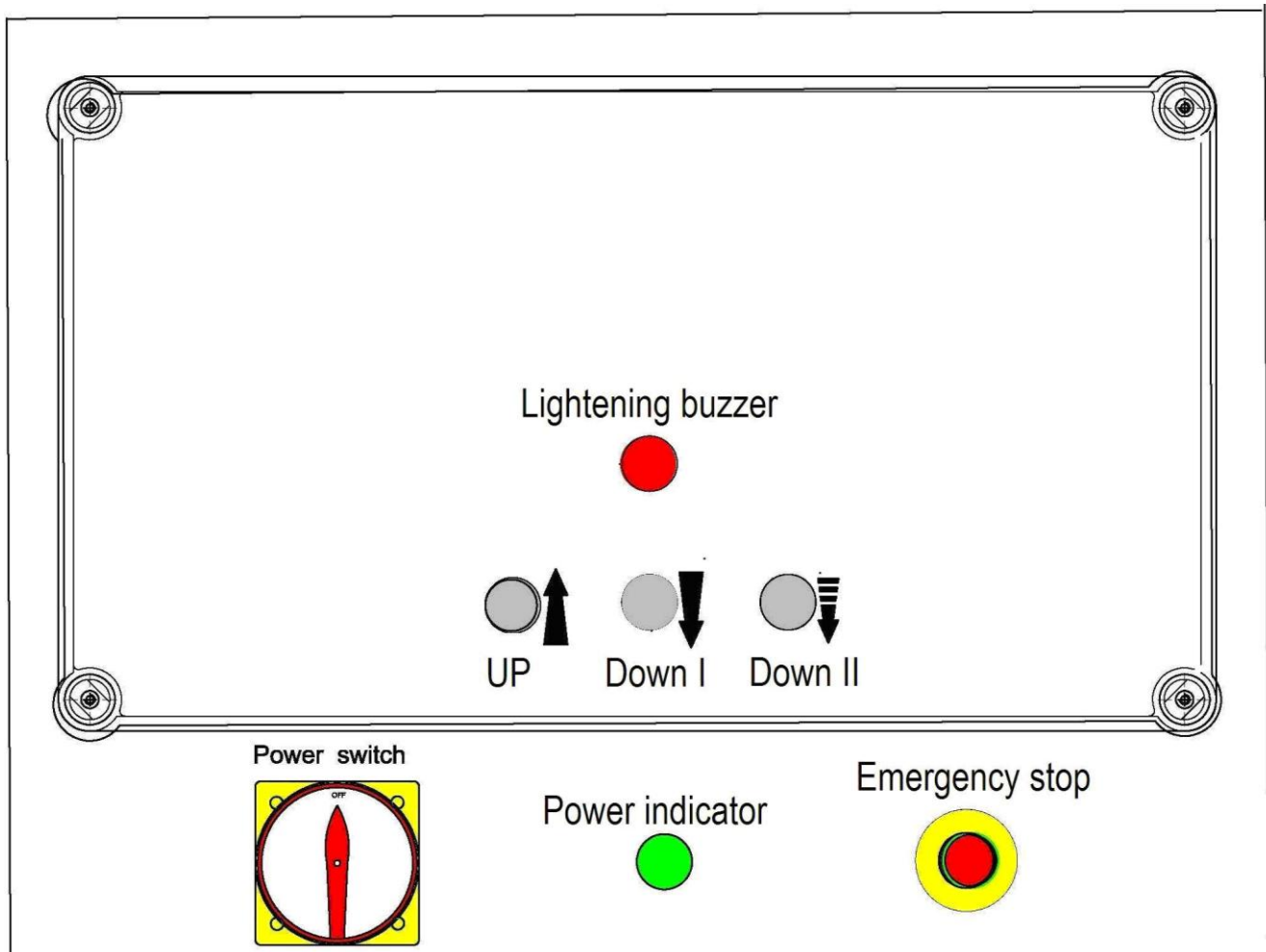

4.3 Flow chart for operation

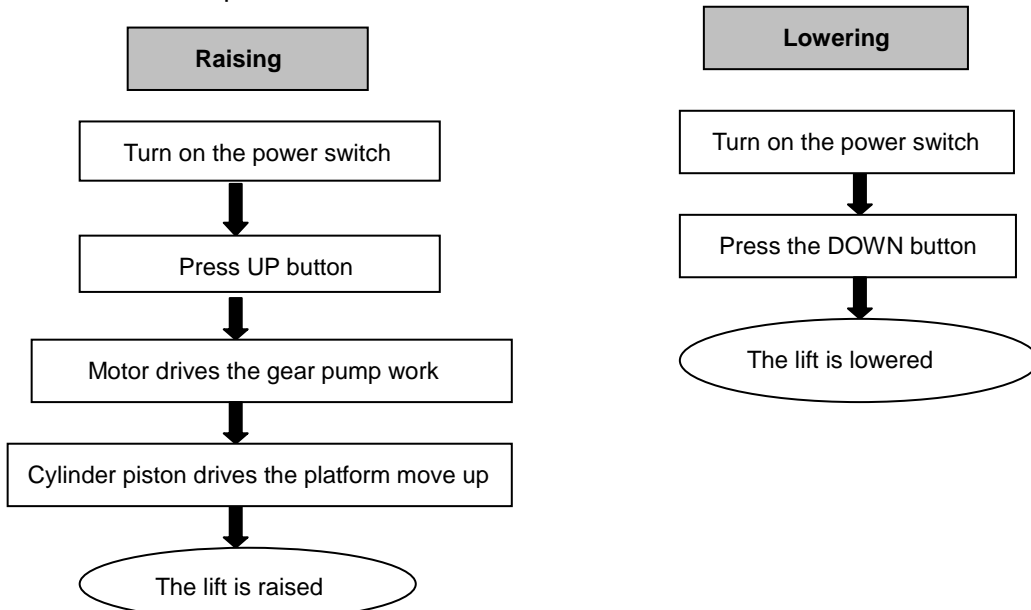

4.4 Operation instructions

Raise the lift

1. Make sure that you have read and understood the operation manual before operation.
2. Drive and park the vehicle midway between two platforms.
3. Place the four rubber pads under the prop-points of the vehicle and ensure car's gravity have fallen on the rubber pads.
4. Press the UP button on the control box until rubber pads have touched the prop-points of vehicle.
5. Keep on pressing the UP button to lift the vehicle a bit higher from the ground and check again if the vehicle is in a safe position.
6. Having raised the vehicle to the required height, operators must press the "Emergency stop" button until the power indicator is off and check again the stability of the vehicle before performing maintenance or repair work,

Lower the lift

1. Switch on.
2. Press the DOWN I button to lower the lift. It will stop lowering when clearance between the platforms and the ground reached to 500mm.
3. Press DOWN II button to continue lowering the platforms. Alarming buzz will be heard unless you stop pressing DOWN II.
4. Drive the vehicle away

4.5 Emergency lowering in case of no power

Pneumatic lock is not engaged

1. Pull up the safety teeth with steel rope to release the safety lock.

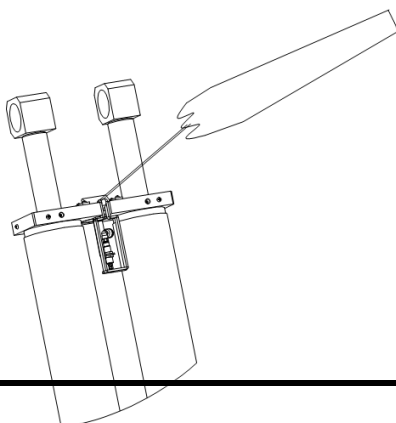

2. Screw loose the core of the solenoid unloading valve fixed on the hydraulic block.

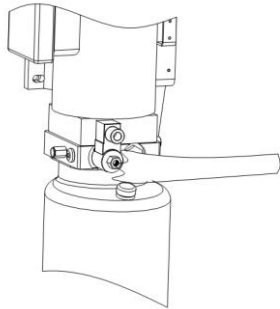

Pneumatic safety lock is engaged.

1. Take down the removable plug from the hydraulic block.

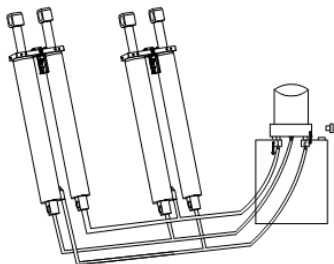

2. Connect the optional hand pump to hydraulic block at the point where the removable plug used to be fitted.

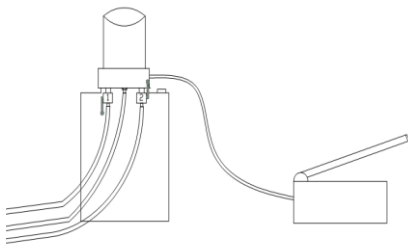

3. Press the handle of the optional hand pump to raise the platform to have the safety teeth unlocked. Then, pull up the safety teeth with steel rope to release the safety lock.

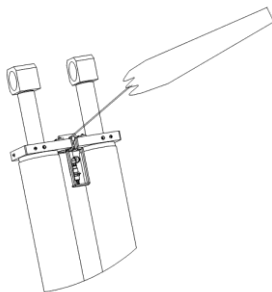

4. Screw loose the core of solenoid unloading valve fixed on the hydraulic block.

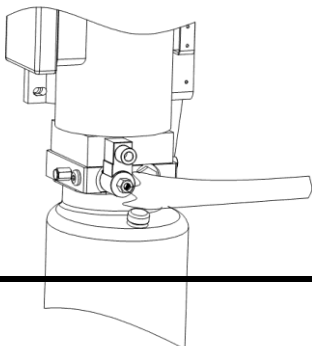

5. Trouble Shooting

ATTENTION: If the trouble could not be fixed by yourself, please do not hesitate to contact us for help .We will offer our service at the earliest time we can. By the way, your troubles will be judged and solved much faster if you could provide us more details or pictures of the trouble.

TROUBLES	CAUSE	SOLUTION
Motor does not run and will not raise	The wire connection is loose.	Check and make a good connection.
	The motor is burnt	Replace it.
	The limit switch is damaged or the wire connection is loose.	Connect it or adjust or replace the limit switch.
Motor runs but will not raise	The motor run reversely.	Check the wire connection.
	Overflow valve is loose or jammed.	Clean or adjust it.
	The gear pump is damaged.	Replace it.
	Oil level is too low.	Add oil.
	The oil hose became loose or dropped off.	Tighten it.
	The cushion valve became loose or jammed.	Clean or adjusts it.
Platforms go down slowly after being raised	The oil hose leaks.	Check or replace it.
	The oil cylinder is not tightened.	Replace the seal.
	The single valve leaks.	Clean or replace it.
	The overflow valve leaks.	Clean or replace it.
	Electrical unloading valve leaks.	Clean or replace it.
Raising too slow	The oil filter is jammed.	Clean or replace it.
	Oil level is too low.	Add oil.
	The overflow valve is not adjusted to the right position.	Adjust it.
	The hydraulic oil is too hot (above 45°).	Change the oil.
	The seal of the cylinder is abraded.	Replace the seal.
Lowering too slow	The throttle valve jammed.	Clean or replace.
	The hydraulic oil is dirty.	Change the oil.
	The anti-surge valve jammed.	Clean it.
	The oil hose jammed.	Replace it.

6. Maintenance

Easy and low cost routine maintenance can ensure the lift work normally and safely. Following are requirements for routine maintenance. You may choose the frequency of routine maintenance by consulting your lift's working conditions and time.

The following parts need to be lubricated.

S/N	DESC
1	Platform slider
2	Joint shaft C
3	Joint shaft B
4	Driving rotor shaft
5	Rotor shaft of base plate
6	Joint shaft D
7	Base plate slider
8	Rotor shaft

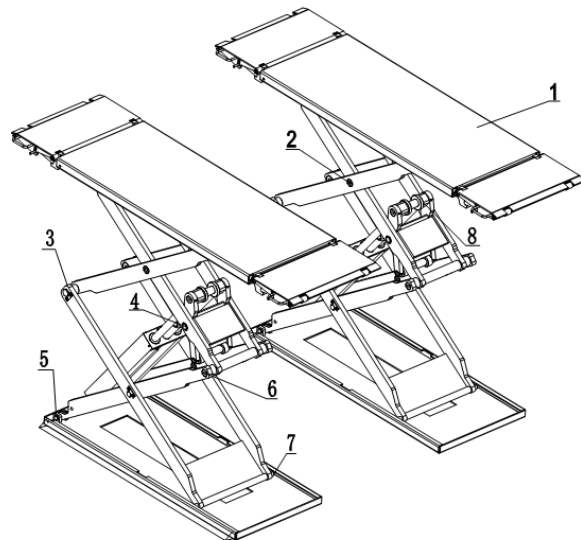

6.1. Daily checking items before operation

The user must perform daily check. Daily check of safety system is very important – the discovery of device failure before action could save your time and prevent you from great loss, injury or casualty.

- Check whether oil hose well connected. No leakage is allowed.
- Check the electric connections .Make sure all connections are in good condition.
- Check whether the expansion bolts well anchored .
- Check if safety teeth and safety block matched well or not.

6.2. Weekly checking items

- Check the flexibility of moving parts.
- Check the working conditions of safety parts.
- Check the amount of oil left in the oil tank. Oil is enough if the carriage can be raised to highest position. Otherwise, oil is insufficient.
- Check whether the expansion bolts well anchored.

6.3. Monthly checking items

- Check whether the expansion bolts well anchored.
- Check the tightness of the hydraulic system and screw firm the joints if it leaks.
- Check the lubrication and abrasion circumstance of moving parts.

6.4. Yearly checking items

- Empty the oil tank and check the quality of hydraulic oil.
- Wash and clean the oil filter.

If users strictly follow the above maintenance requirements, the lift will keep in a good working condition and meanwhile accidents could be avoided to a large extent.

7. ANNEX

Annex 1, Packing List of the whole lift

S/N	Name	Drawing#/Size	Description	Qty
1	Lift	6501-01	Component	1
2	Protection cover assembly	6501-A06-B02	Component	1
3	Cover plate A	6501-A9	Q235A	1
4	Cover plate B	6501-A10	Q235A	1
5	Cover plate C	6501-A11	Q235A	1
6	Expansion bolt	M16*125	Standard piece	8
7	Expansion bolt	M6*50	Standard piece	12
8	Control box	6501-A12	Assembly	1

Annex2, Overall diagram

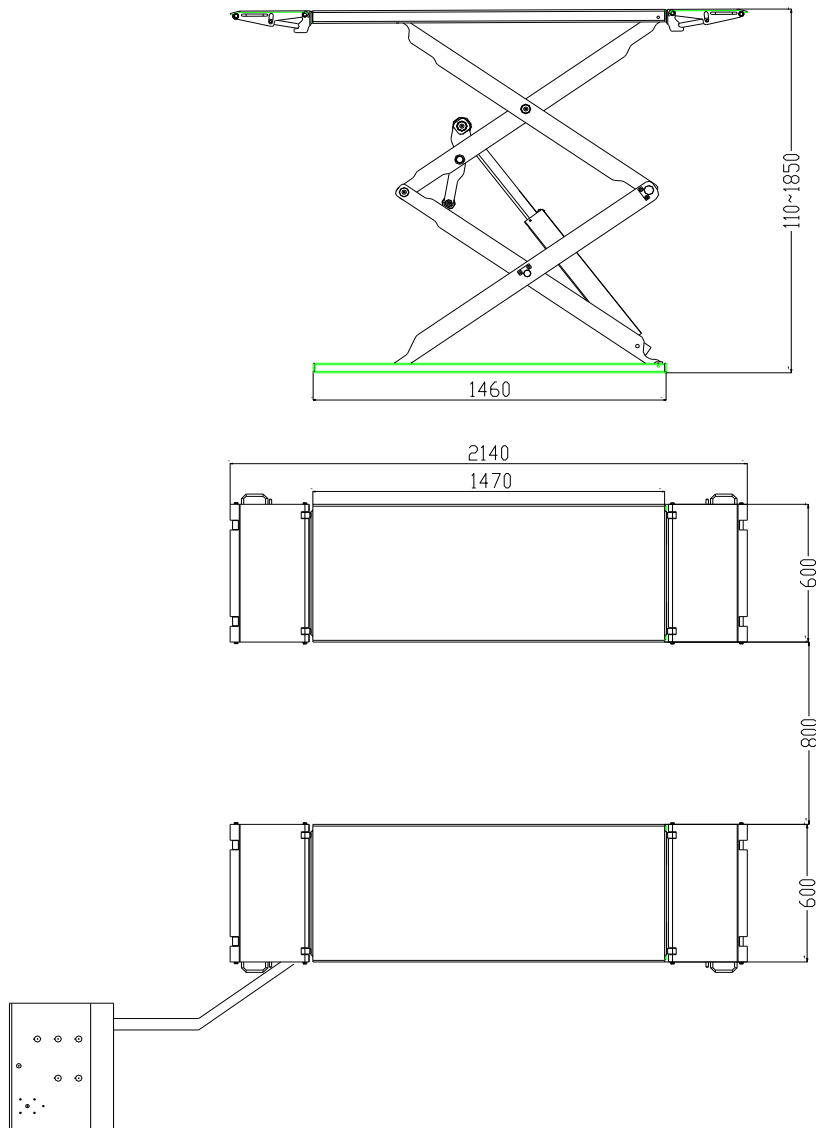

Annex3, Diagram for ground fixing

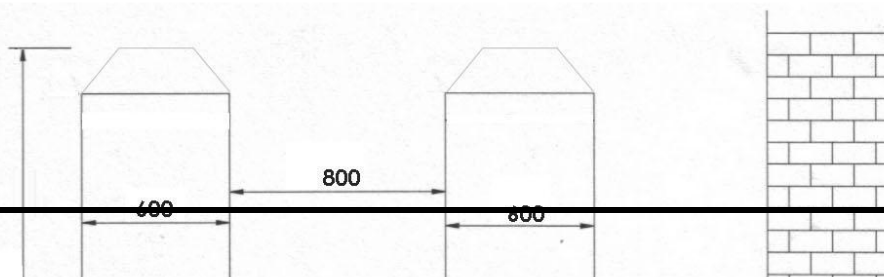
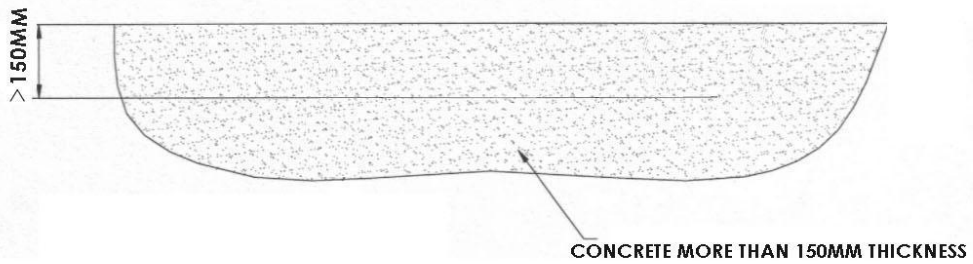

Annex 4, Diagram for oil hose connection

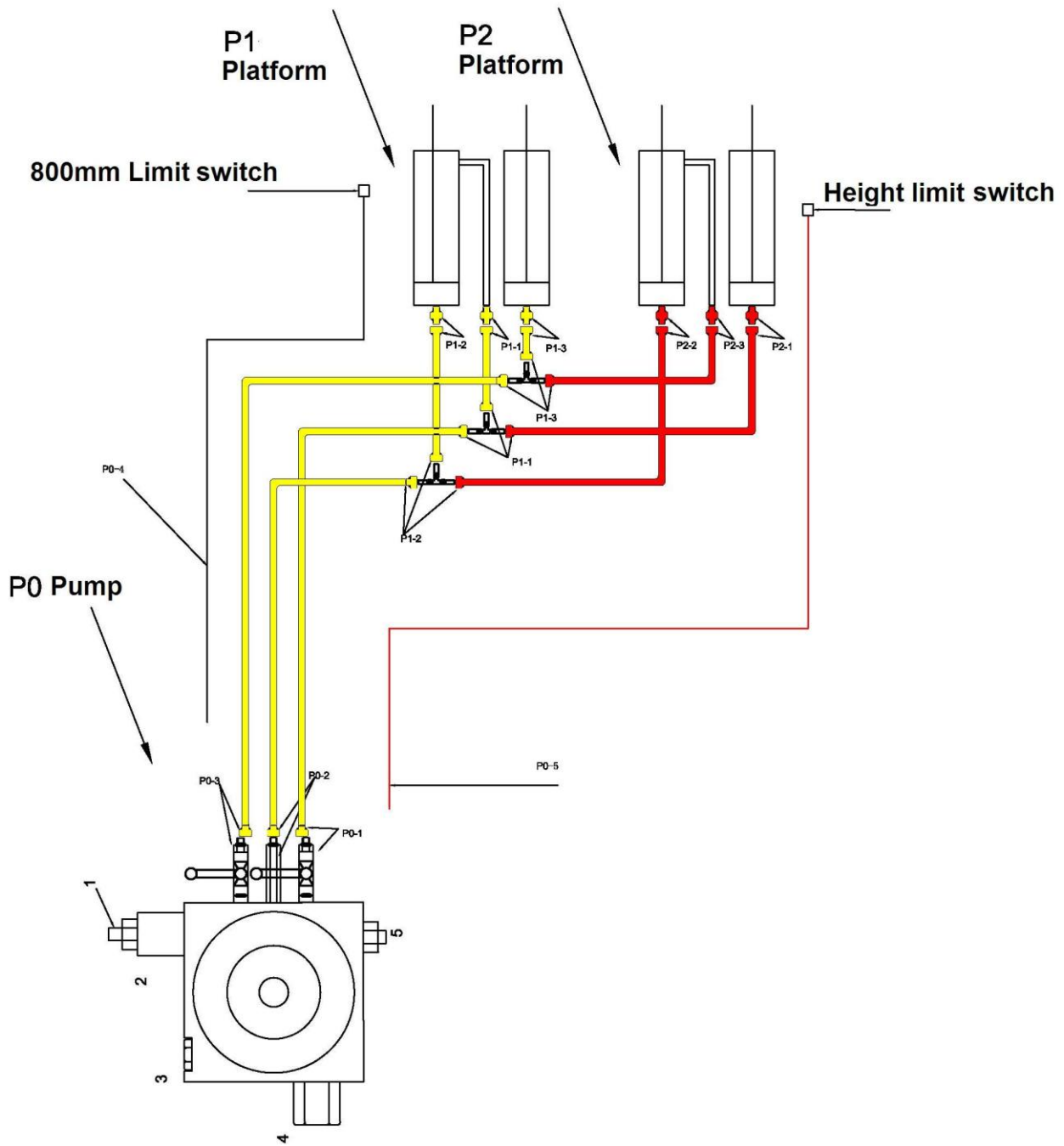

Annex 5, Hydraulic working system

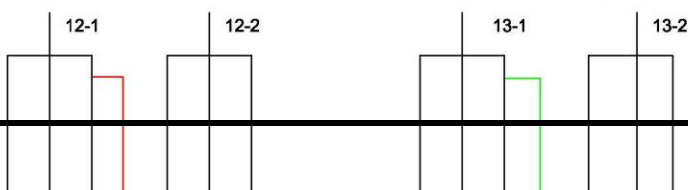

- 1 .Emergent unloading valve
2. Electrical unloading valve
3. One-way valve
4. Overflow valve
5. Lowering throttle valve
6. Oil supplementing ball valve
7. Oil supplementing ball valve
8. Cushion valve
9. Gear pump
10. Oil pump motor
11. Oil filter
12. Driving cylinder
13. Assistant cylinder
14. Coupling
15. Anti-surge valve

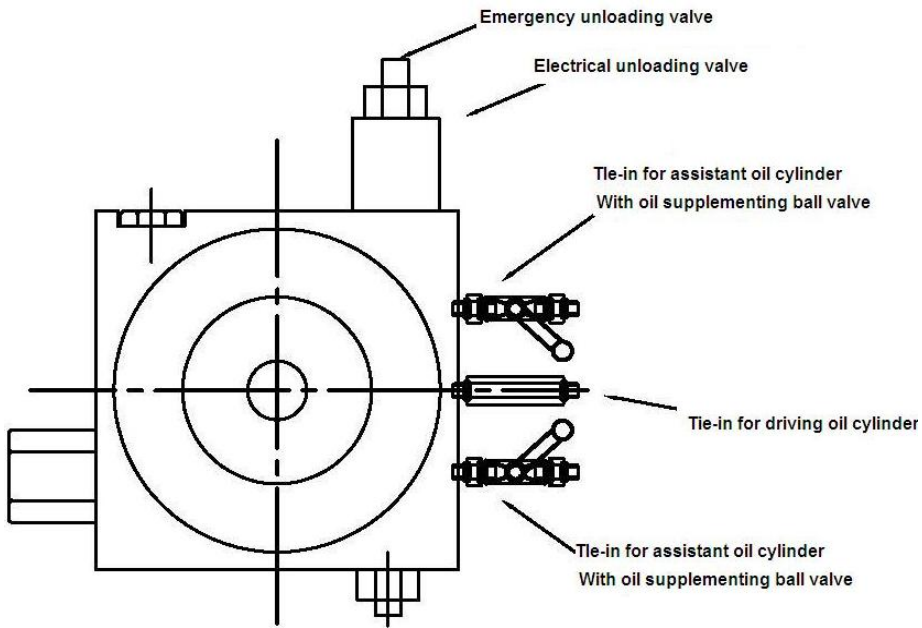

Annex6, Wiring diagram

Single phase

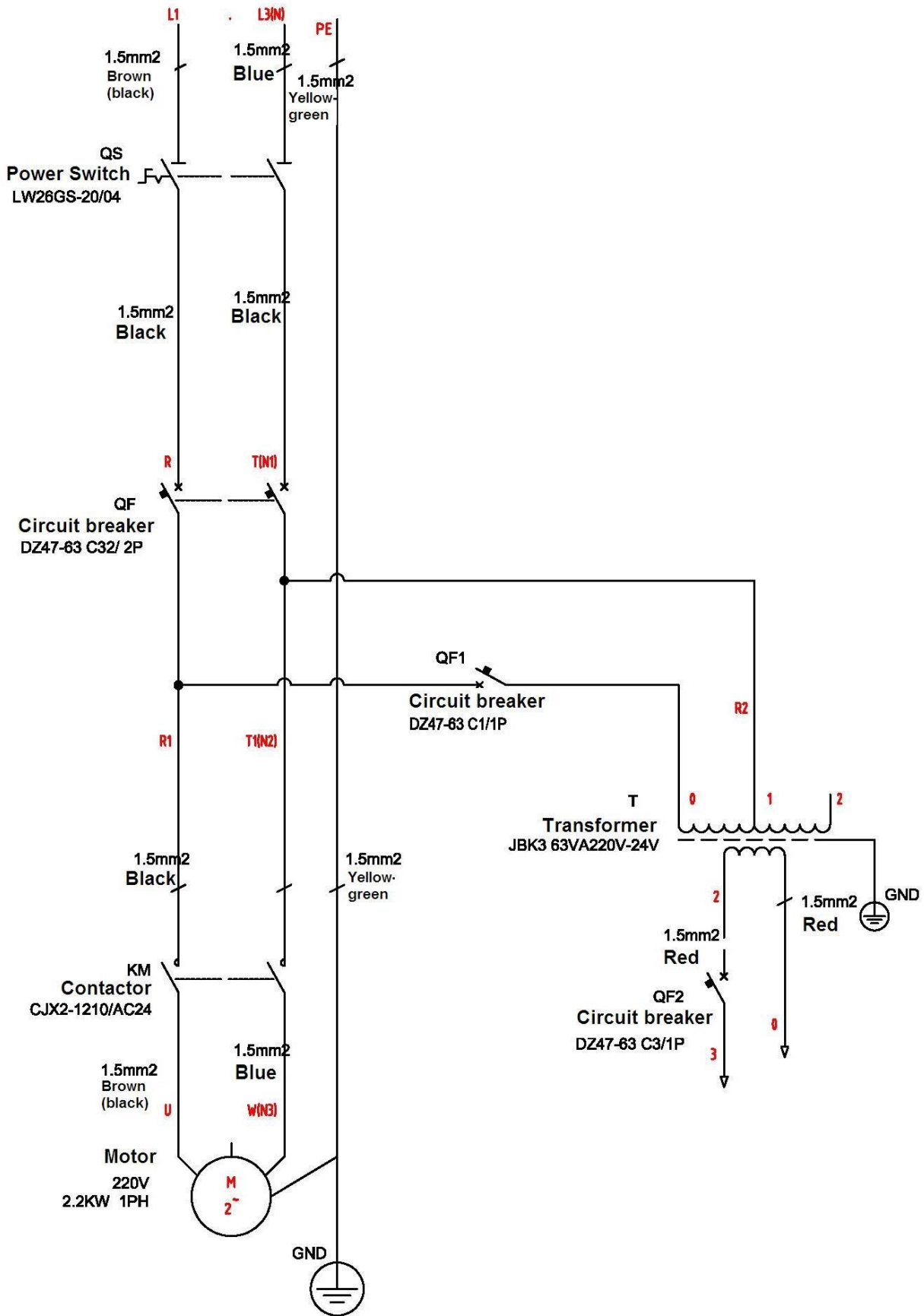

Three phase

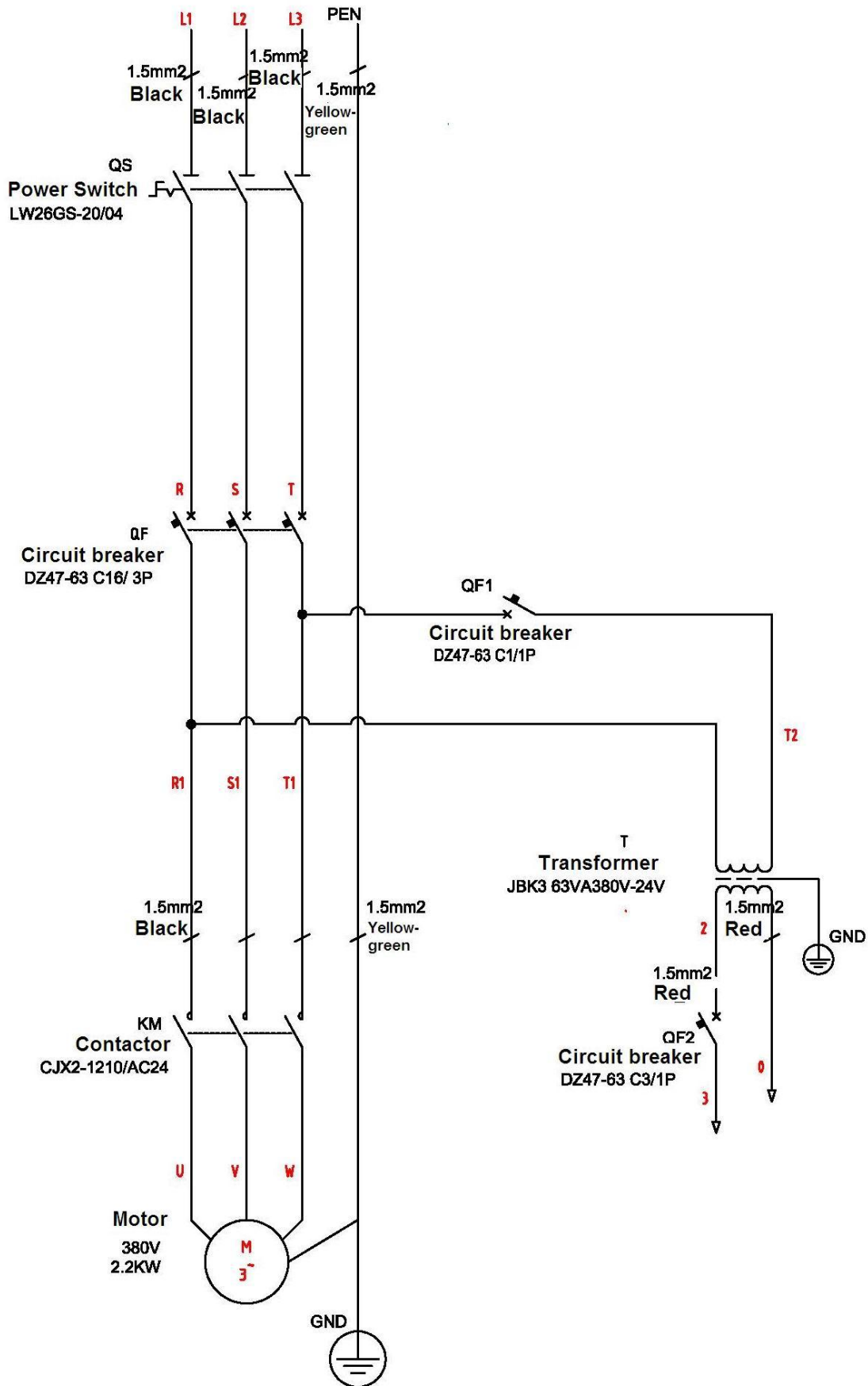

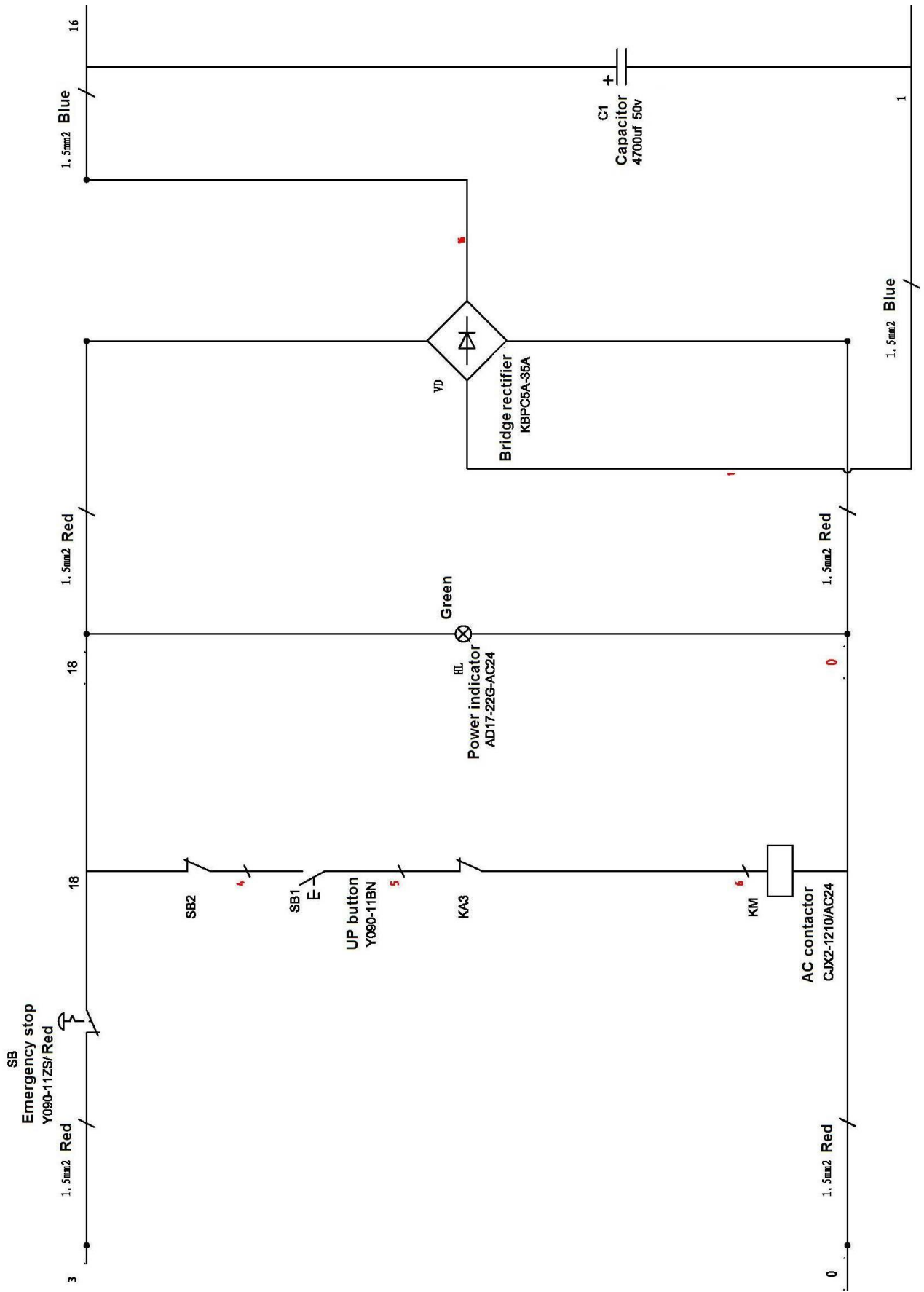

VEHICLE LIFT SPECIALIST

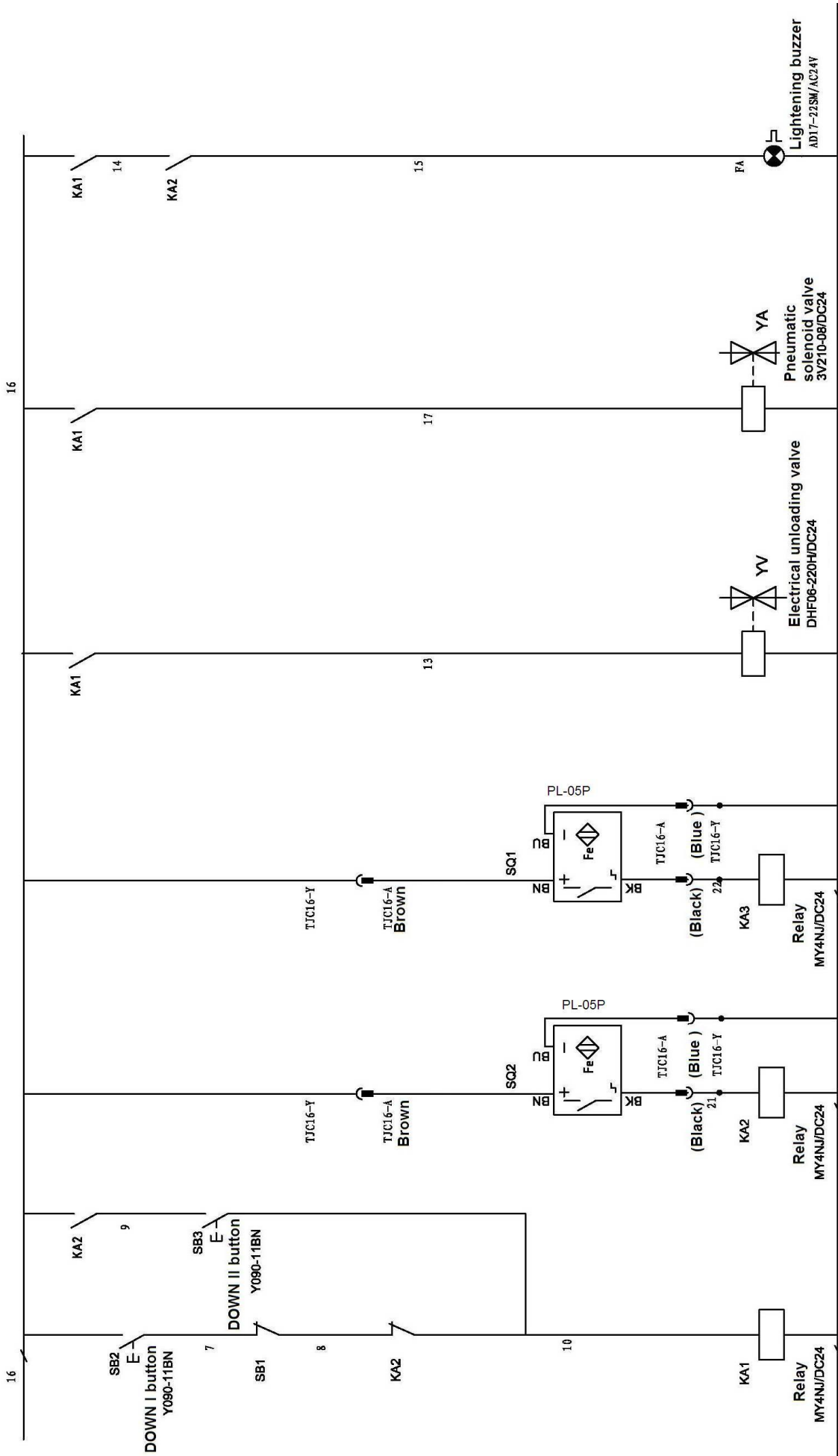

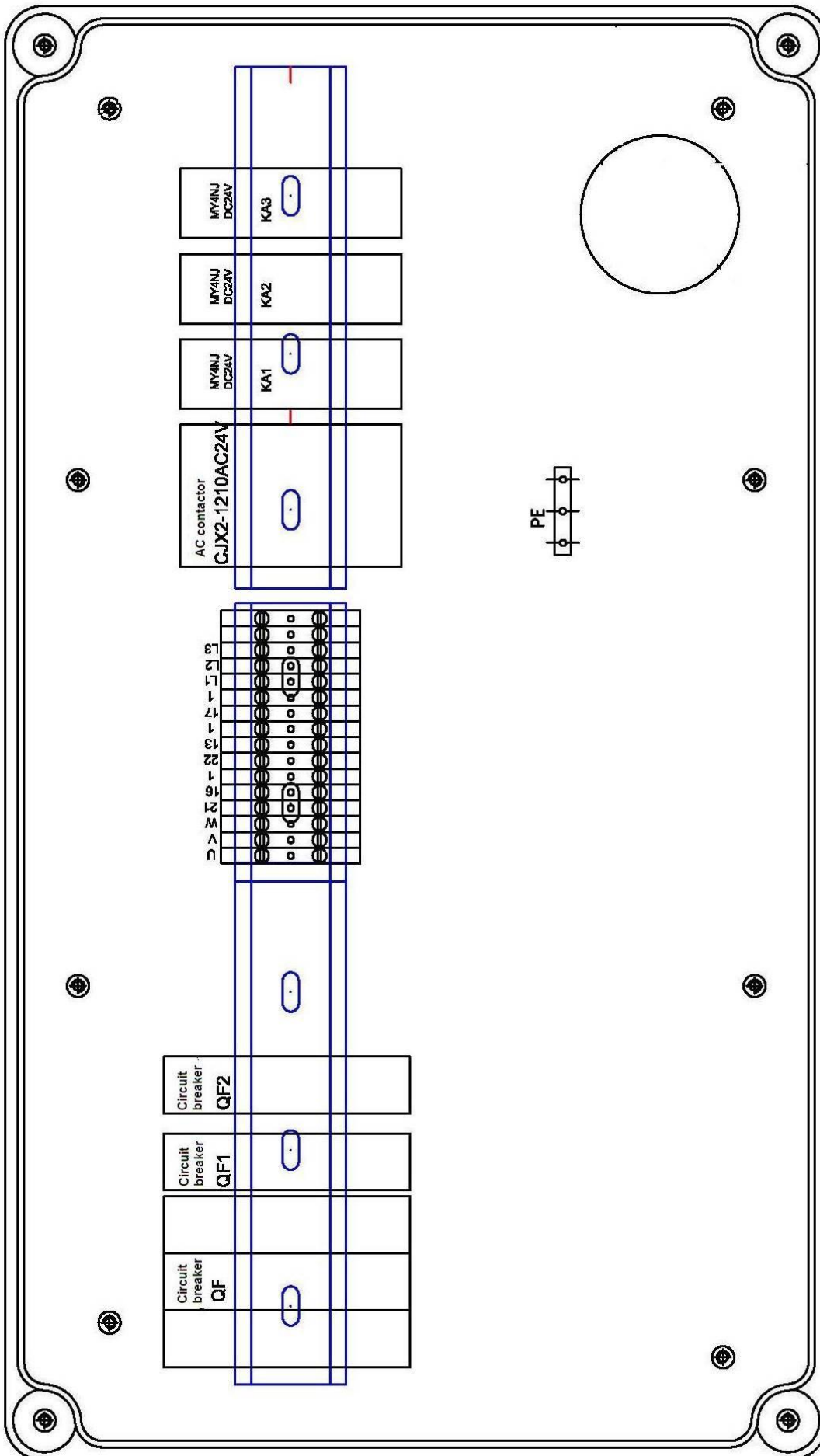

Annex7,Diagram for air supply connection

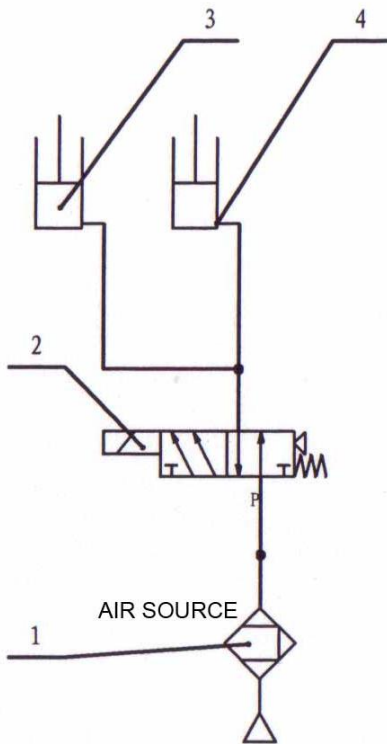

- 1、 Air Filter
- 2、 Solenoid Directional Valve
- 3、 Driving cylinder locking
- 4、 Assistant cylinder locking

Annex 8, Separate diagrams for the lift

For the pump:

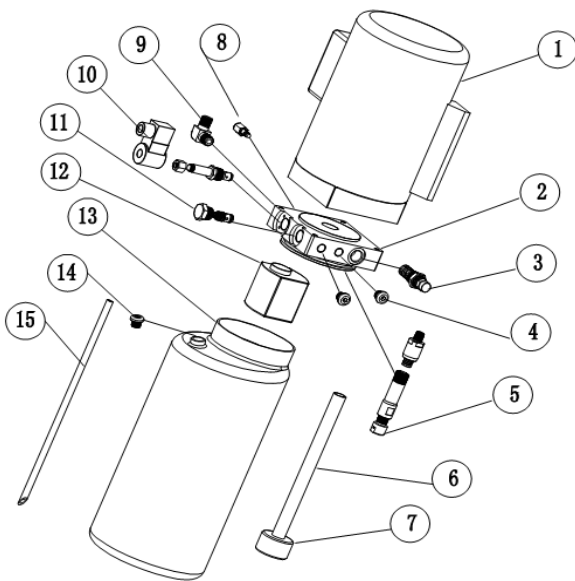

S/N	DESCRIPTION	QTY
1	Motor	1
2	Hydraulic block	1
3	Overflow valve	1
4	Fitting	2
5	Cushion valve	1
6	Absorbing oil hose	1
7	Oil filter	1
8	Throttle valve	1
9	Oil hose tie-in	1
10	Electrical unloading valve	1
11	One-way valve	1
12	Gear pump	1
13	Oil tank	1
14	Oil tank cover	1
15	Oil back hose	1

For mechanical assembly

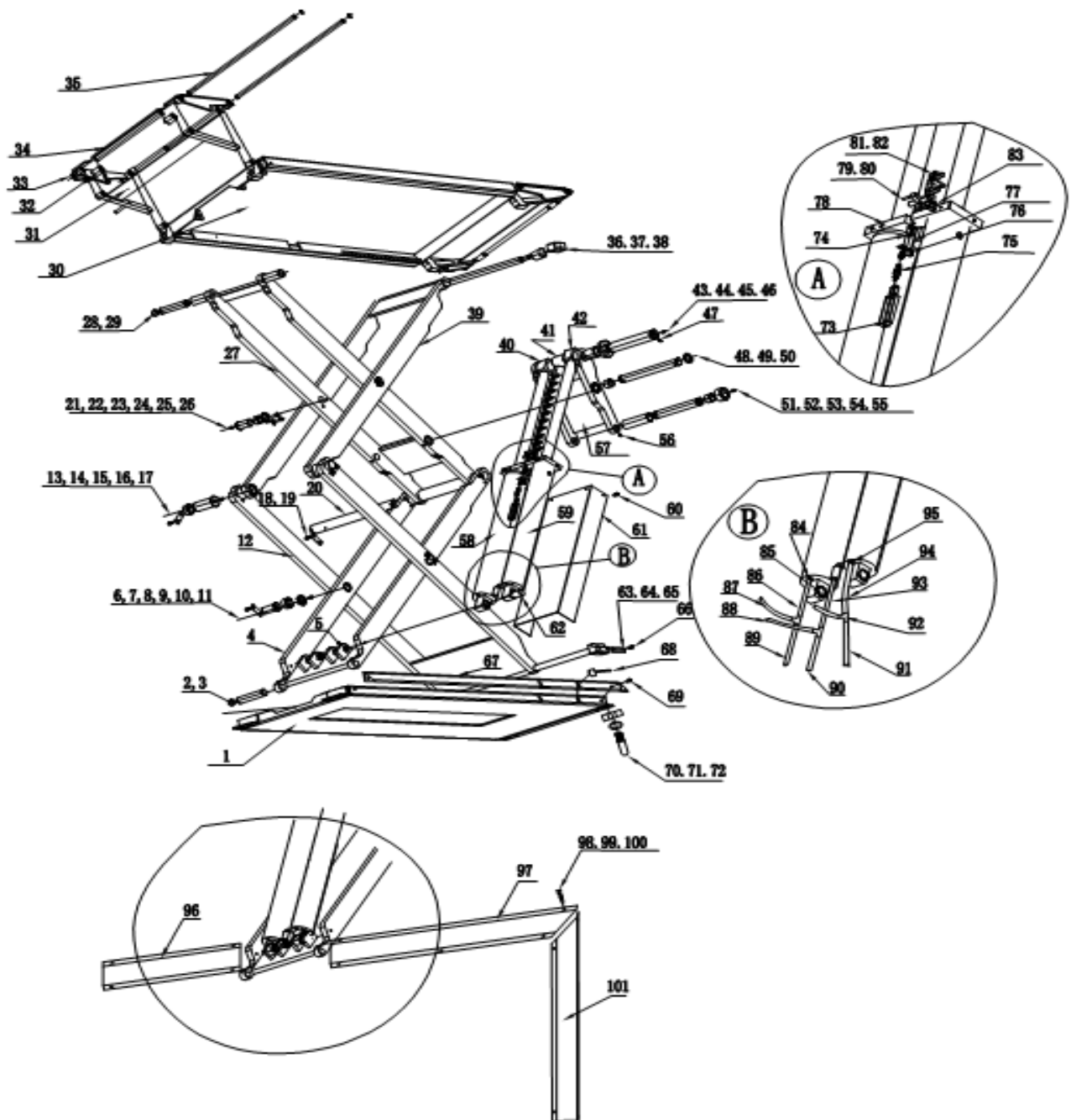

S/N	Material#	Name	Drawing#	Description	Qty	Note
1	622001	Welding base plate A	EE-6501-A1	Welding	2	
2	219007	Circlip 28	GB/T894.1-1986	Standard	4	
3	246028	Rotor shaft	EE-6501-A1-B5	45#	4	
4	622004	Welding bracket C	EE-6501-A2-B3	Welding	2	
5	227003	Stop screw M6*10	GB/T78-2000	Standard	16	Total quantity
6	214016	Cross sunken head bolt M8*16	GB/T819.1-1986	Standard	32	Total quantity
7	246063	Clip	EE-6501-A2-B5	Q235A	16	Total quantity
8	246009	Joint shaft C	EE-6501-A2-B6	45#	4	
9	220034	Oilless bearing 3020	SF-1	Standard	8	Total quantity

VEHICLE LIFT SPECIALIST

S/N	Material#	Name	Drawing#	Description	Qty	Note
10	246012	Thick spacer	EE-6501-A2-B7	Q235A	8	
11	230002	Straight oil cup M8*1	JB/T7940.1-1985	Standard	32	Total quantity
12	622002	Welding bracket B	EE-6501-A2-B1	Welding	2	
13	214016	Cross sunken head bolt M8*16	GB/T819.1-1986	Standard		Same as item 6
14	246063	Clip	EE-6501-A2-B5	Q235A		Same as item 7
15	220035	Oilless bearing 4020	SF-1	Standard	4	
16	246009	Joint shaft B	EE-6501-A2-B9	45#	4	
17	230002	Straight oil cup M8*1	JB/T7940.1-1985	Standard		Same as item 11
18	214016	Cross sunken head bolt M8*16	GB/T819.1-1986	Standard		Same as item 6
19	246063	Clip	EE-6501-A2-B5	Q235A		Same as item 7
20	246011	Joint shaft D	EE-6501-A2-B12	45#	2	
21	230002	Straight oil cup M8*1	JB/T7940.1-1985	Standard		Same as item 11
22	246009	Joint shaft C	EE-6501-A2-B6	45#	4	
23	220034	Oilless bearing 3020	SF-1	Standard		Same as item 9
24	246012	Thin spacer	EE-6501-A2-B8	Q235A	4	
25	214016	Cross sunken head bolt M8*16	GB/T819.1-1986	Standard		Same as item 6
26	246063	Clip	EE-6501-A2-B5	Q235A		Same as item 7
27	622003	Welding bracket A	EE-6501-A2-B2	Standard	2	
28	219002	Circlip 25	GB/T894.1-2000	Standard	8	
29	246025	Rotor shaft	EE-6501-A5-B2	45#	4	
30		Welding platform	EE-6501-A5-B3	Welding	2	
31	622011	Supporting rod assembly	EE-6501-A5-B1-	Welding	1	
32	252025	Small idler wheel	MR30-A22-B5	Nylon 1010	4	
33	219002	Circlip 25		Standard	4	
34	246027	Ramp A assembly	EE-6501-A5-B4	Welding	2	
35	246086	Shaft of ramp	EE-6501-A5-B1-	45#	4	
36	246018	Rotor shaft	EE-6501-A2-B15	45#	2	
37	246016	Idler wheel	EE-6501-A2-B16	Q235A	4	
38	247002	Padding block	EE-6501-A2-B17	Nylon	4	
39	622002	Welding bracket B	EE-6501-A2-B1	Welding	2	
40	246020	Connector A of oil cylinder	EE-6501-A4-B11		2	
41	246067	Safety teeth	EE-6501-A4-B2	Welding	2	
42	246021	Connector B of oil cylinder	EE-6501-A4-B11		2	
43	230002	Straight oil cup M8*1	JB/T7940.1-1985	Standard		Same as item 11
44	246029	Rotor shaft of oil cylinder	EE-6501-A3-B1	45#	2	
45	246013	Idler wheel of oil cylinder	EE-6501-A4-B12	45#	4	
46	220013	Oilless bearing 4040	SF-1	Standard	4	
47	227003	Stop bolt M6*10	GB/T78-2000	Standard	16	Same as item 5
48	246012	Thin spacer	EE-6501-A2-B8	Q235A	4	
49	246030	Rotor wheel	EE-6501-A3-B6	45#	2	
50	220005	Oilless bearing 3025	SF-1	Standard	4	
51	230002	Straight oil cup M8*1	JB/T7940.1-1985	Standard		Same as item 11
52	246015	Start idler wheel	EE-6501-A3-B4	Q235A	4	
53	220037	Oilless bearing 3530	SF-1	Standard	4	
54	246030	Start rotor shaft	EE-6501-A3-B3	45#	2	
55	246017	Circlip	EE-6501-A3-B5	Q235A	2	
56	227003	Stop bolt M6*10	GB/T78-2000	Standard	16	Same as item 5
57	622006	Start rotor plate	EE-6501-A3-B2	Welding	2	
58	246034	Driving oil cylinder		Assembly	2	

VEHICLE LIFT SPECIALIST

S/N	Material#	Name	Drawing#	Description	Qty	Note
59	246035	Assistant oil cylinder		Assembly	2	
60	215008	Cross round headed bolt M5*10	GB/T78-2000	Standard	4	
61	422032	Sheath of oil cylinder	EE-6501-A4-B14	Q235A	2	
62	246022	Shaft oil cylinder	EE-6501-A4-B9	45#	4	
63	422055	Position limit block	EE-6501-A2-B19	Q235A	1	
64	246060	Slider	EE-6501-A2-B18	Nylon 1010	4	One with M8 hole
65	246019	Shaft	EE-6501-A2-B11	45#	2	
66	214016	Cross flat head bolt M8*16	GB/T78-2000	Standard	2	
67	622010	Protection cover	EE-6501-A6-B2	Welding	1	
68	622010	Limit switch		Assembly	2	Lightening style
69	211027	Inside hex bolt M6*12	GB/T78-2000	Standard	4	
70	216008	Hex nut M16	GB/T41-2000	Standard	8	With expansion bolt
71	217011	Washer 16		Standard	8	With expansion bolt
72	222003	Expansion bolt M16*120		Standard	8	
73	422045	Safety block connection	EE-6501-A4-B5	Q235A	2	
74	215008	Cross round headed bolt M5*10	GB/T78-2000	Standard	2	
75	221012	Air cylinder	AA6*10	Assembly	2	
76		Bent air hose connector	SPL06-M5	Assembly	2	
77	246065	Fixing plate of air cylinder	EE-6501-A4-B6	Q235A	2	
78	246023	Oil cylinder flange	EE-6501-A4-B3	45#	2	
79	224060	Post shaft A4*14	GB/T119.1-2000	Standard	2	
80	422035	Safety block	EE-6501-A4-B4	45#	2	
81	215008	Cross round headed bolt M5*10	GB/T78-2000	Standard	8	
82		Pressure block	EE-6501-A4-B13	Q235A	4	
83	215008	Cross round headed M5*10	GB/T78-2000	Standard	8	
84		Connector A		Assembly	2	With throttle valve
85	220006	Oilless bearing 2840	SF-1-2840	Standard	4	
86	247003	Oil hose	EE-6501-A4-B10	Assembly	1	0.16m
87	247018	Oil hose		Assembly	1	1.6m
88	247006	Oil hose		Assembly	2	1.65m
89	247007	Oil hose		Assembly	1	2.5m
90	247007	Oil hose		Assembly	1	2.5m
91	247007	Oil hose		Assembly	1	2.5m
92	250044	3-way tie-in	EE-6501-A4-B7	45#	3	
93	247004	Oil hose	EE-6501-A4-B10	Assembly	1	0.18m
94	247005	Oil hose		Assembly	1	0.20m
95	246036	Connector B	EE-6501-A4-B16	45#	4	
96	422062	Sheath of oil hose	EE-6501-A9	Q235A	1	
97	422063	Sheath A of oil hose	EE-6501-A10	Q235A	1	
98	216003	Hex nut M6		Standard	14	With expansion bolt
99	217001	Washer 6		Standard	14	With expansion bolt
100	222009	Expansion bolt M6*40		Standard	14	
101	422064	Sheath of oil hose	EE-6501-A11	Q235A	1	

Annex 9, Spare parts list

Spare parts list-electrical system

S/N	Material No.	Name	Spec.	Unit	Qty/set	Pictures
1	321001	Power switch	LW26GS-20/04	Pcs	1	
2	328064	Button	Y090	Pcs	3	
3	328003	Power indicator	AD17-22G-AC24	Pcs	1	
4	320001	Transformer	JBK-63VA220V-24V	Pcs	1	Same outlook as item7
5	320002	Transformer	JBK-63VA230V-24V	Pcs	1	Same outlook as item7
6	320003	Transformer	JBK-63VA240V-24V	Pcs	1	Same outlook as item7
7	320004	Transformer	JBK-63VA380V-24V	Pcs	1	
8	320005	Transformer	JBK-63VA400V-24V	Pcs	1	Same outlook as item7
9	320006	Transformer	JBK-63VA415V-24V	Pcs	1	Same outlook as item7
10	328005	AC contactor	CJX2-1210/AC24	Pcs	1	
11	327004	Circuit breaker	DZ47-63 C16 /3P	Pcs	1	
12	327002	Circuit breaker	DZ47-63 C32 /2P	Pcs	1	

VEHICLE LIFT SPECIALIST

S/N	Material No.	Name	Spec.	Unit	Qty/set	Pictures
13	327003	Circuit breaker	DZ47-63 C3 /1P	Pcs	1	
14	313016	Pneumatic valve	3V210-08/DC24	Pcs	1	
15	321005	Limit switch	PL-05P	Pcs	2	
16	328026	Bridge rectifier	KBPC5A-35A	Pcs	1	
17	328014	Capacitor	4700UF/50V	Pcs	1	
18	328074	Control box	Bigger	Pcs	1	
19	326014	Relay	MY4NJ/DC24	Pcs	3	
20	326004	Relay holder	PYF14AE	Pcs	1	

Spare parts list---machine part

S/N	Material #	Name	Drawing#	Description	Qty	Note
7	246063	Clip	EE-6501-A2-B5	Q235A	16	
10	246012	Thick spacer	EE-6501-A2-B7	Q235A	8	
11	230002	Straight oil cup M8*1	JB/T7940.1-1985	Standard	32	
24	246012	Thin spacer	EE-6501-A2-B8	Q235A	4	
38	247002	Padding block	EE-6501-A2-B17	Nylon	4	
64	246060	Slider	EE-6501-A2-B18	Nylon	4	
67	622010	Protection sheath	EE-6501-A6-B2	Welding	1	
68	622010	Limit switch		Assembly	2	
73	422045	Safety block connector	EE-6501-A4-B5	Q235A	2	
75	221012	Air cylinder	AA6*10	Assembly	2	
77	246065	Fixing plate of oil cylinder	EE-6501-A4-B6	Q235A	2	
82		Baffle plate	EE-6501-A4-B13	Q235A	4	
96	422062	Sheath of oil hose	EE-6501-A9	Q235A	1	
97	422063	Sheath A of oil hose	EE-6501-A10	Q235A	1	
101	422064	Sheath of oil hose	EE-6501-A11	Q235A	1	

Annex10 , Size and weight requirements on vehicles

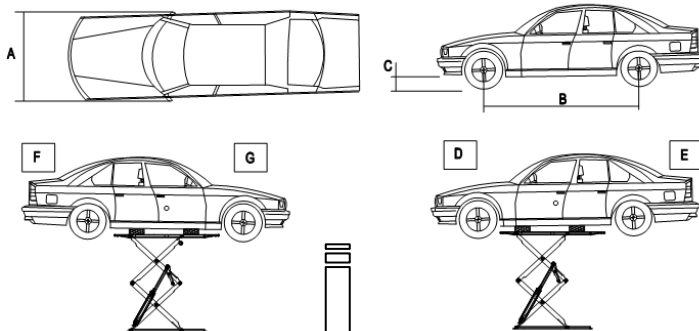

Model No.	A (mm)	B (mm)	C (mm)	D (T)	E (T)	F (T)	G (T)
EE-6501	1900	2000	110	1.8	1.2	1.2	1.8