

# ***CB956***

WHEEL BALANCER USER MANUAL

***Pls read this manual before operation***

# CONTENT

## TABLE OF CONTENTS

<b>1. reface</b> .....	1
WARNING .....	1
INTRODUCTION.....	1
INSTALLATION.....	1
SAFETY REGULATION.....	2
<b>2.CB956 BALANCE INSTALLATION &amp; OPERATION MANUAL</b> .....	3
2.1PROTECTIVE COVER ASSEMBLY.....	3
2.2BALANCE SHAFT ASSEMBLY.....	3
2.3 EQUIPPING POWER SOURCE .....	4
<b>3 .CB956SERIES WHEEL BALANCER TECHNICAL PERFORMANCE</b> .....	4
3.1PERORMANCE & CHARACTERISTIC.....	4
3.2MAIN TECHNICAL SPECIFICATION .....	4
3.3WORKING PRINCIPLE .....	4
<b>4.TRANSPORTATION &amp; INSTALLATION</b> .....	5
4.1 TRANSPORTATION .....	5
4.2 INSTALLATION .....	5
<b>5.SATETY &amp;PREVENTION</b> .....	5
<b>6.CONFIGURATION &amp; USE</b> .....	7
6.1CONFIGURATION .....	7
6.2 DISPLAY PANEL.....	7
6.3 BASIC OPERATION.....	9
6.4 VALUE INPUT .....	10
6.5 RESIDUAL UNBALANCE VALUE DISPLAY .....	11
6.6 BALANCE MODE & ALU BALANCE MODE SELECT .....	11
6.7 SUPPLEMENTARY EXPLANATION .....	13
<b>7.PROGRAM SETUP</b> .....	14

7.1PROGRAM FUNCTION INTRODUCTION .....	14
7.2ERROR .....	18
7.3PRESS SENSOR INSTALLATION AND WIRING.....	18
7.4GENERAL TROUBLESHOOTING & SOLUTION.....	19
7.5STANDARD ACCESSORIES.....	20
<b>8. MAINTENANCE.....</b>	<b>21</b>
<b>9. OPERATION DETAILED DESCRIPTION.....</b>	<b>24</b>
HOW TO BALANCE A WHEEL.....	24
APPENDIX 1LAYOUT OF THE POWER SUPPLY CARD.....	25
APPENDIX 2 WIRING DIAGRAM.....	25

## 1.reface

### WARNING

During this period, the manufacturer will repair or replace the parts returned or the machine itself, sustaining the costs but not accepting responsibility for normal wear and tear, incorrect use or transportation, or failure to carry out maintenance. The manufacturer will not inform the customer about any improvements to the products or the upgrading of the production line.

### INTRODUCTION

The purpose of this manual is to provide the owner and operator of this machine with a set of safe and practical instructions for the use and maintenance of the wheel balancer.

If such instructions are carefully followed, the machine will offer you the levels of efficiency and duration.

The following paragraphs define the levels of danger regarding the machine.



**DANGER:** Refers to immediate danger with the risk of serious injury or death.



**WARNING:** Dangers or unsafe procedures that can cause serious injury or death.



**ATTENTION:** Dangers or unsafe procedures that can cause minor injuries or damage to property.

Read these instructions carefully before using the machine. Keep this manual and the illustrated materials

supplied with the equipment in a folder near the place of operation so as to allow the machine operators to consult the documentation at any time.

The manual is only to be considered valid for the machine serial number and model stated on the attached nameplate.

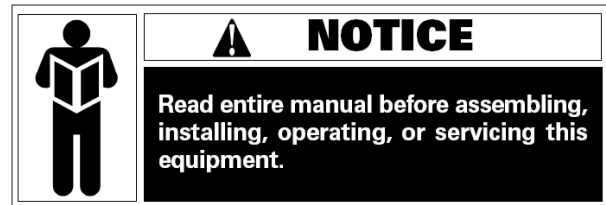

The instructions and information described in this manual must always be complied with: the operator will be held responsible for any operation not specially described and authorized in this manual.

Some of the illustrations contained in this booklet have been taken from pictures of prototypes: standard production machines may differ slightly in certain respects. These instructions are for the attention of personnel with basic mechanical skills. We have therefore condensed the descriptions of each operation by omitting detailed instructions regarding, for example, how to loosen or tighten the fixing devices. Do not attempt to perform operations unless properly qualified or with suitable experience. If necessary, please contact an authorized Service Centre for assistance.

### INSTALLATION



Take the utmost care when unpacking, assembling, lifting and setting up the machine as indicated below. Failure to observe these instructions can damage the machine and compromise the operator's safety. Remove the original packing materials after positioning them as indicated on the packaging.



All regulations in force concerning safety at work must be complied with when choosing the installation position. In particular, the machine must only be

installed and operated in protected environments where there is no risk of exposure to dripping.

**IMPORTANT:** for the correct and safe operation of the machine, the lighting level in the place of use should be at least 300 lux.

Environmental operating conditions must comply with the following requirements:

- HR: 30% —80% (without condensation);
- temperature range: 0° —+50° C.



The floor must be strong enough to support a load equal to the weight of the equipment plus the maximum load allowed.



The machine must not be operated in potentially explosive atmospheres.

#### **SAFETY REGULATIONS**



Failure to comply with the instructions and danger warnings can cause serious injuries to the operator or other persons.

Do not operate the machine until you have read and understood all the danger/warning notices in this manual.

The correct use of this machine requires a qualified and authorized operator. This operator must be able to understand the manufacturer's written instructions, be suitably trained and be familiar with the safety procedures and regulations. Operators are forbidden to use the machine under the influence of alcohol or drugs that could affect his/her physical and mental capacity.

The following conditions are essential:

- read and understand the information and instructions described in this manual;

- have a thorough knowledge of the features and characteristics of the machine;

- keep unauthorized persons well clear of the working area;

- make sure that the machine has been installed in compliance with all relevant standards and regulations in force;

- make sure that all machine operators are suitably trained, that they are capable of using the machine correctly and safely and that they are adequately supervised during work;

- do not touch power lines or the inside of electric motors or any other electrical equipment before making sure that they have been powered off;

- read this booklet carefully and learn how to use the machine correctly and safely;

- always keep this user manual in a place where it can be readily consulted and do not fail to refer to it.



Do not remove or deface the DANGER, CAUTION, WARNING or INSTRUCTION decals. Replace any missing or illegible decals. If any decals have become detached or damaged, it is possible to obtain them from your nearest reseller.

-Observe the unified industrial accident prevention regulations relating to high voltages and rotating machinery whenever the machine is in use or being serviced.

- Any unauthorized changes or modifications made to the machine automatically release the manufacturer from any liability in the case of damage or accidents

resulting from such changes or modifications .



Meaning of the decals (including the one indicating caution)



**Lightning symbol**  
This decal, positioned on the back of the machine, indicates where to insert the power supply cable and warns the user to pay attention to his safety.



**Warning for rotating machine part**  
This decal, positioned next to the balancing shaft, reminds the user that this is a rotating part and is therefore dangerous and should not be touched with the hands. The arrow indicates the rotation direction.



**Grounding symbol**  
This decal, positioned on the rear left side of the machine, indicates where to connect the ground wire.

## II CB956 WHEEL BALANCER

### INSTALLATION & OPERATION

#### MANUAL

Before installation and use of the wheel balancer, you should carefully read this installation and operation manual. And keep this manual in hand for reference at any time. You should be sure that all the operators have read this manual to guarantee the most perfect functions of the machine and meanwhile the safety.

ATTENTION:

			
Wear protective glove	Read manual before operation	wear protective goggle	power off the electrical source of the machine during

			maintenance
--	--	--	-------------

#### 2.1 PROTECTIVE HOOD INSTALLATION

Before operating the machine, please connect the protective hood by following the indication Of the Fig1 if you need to install the protective hood.

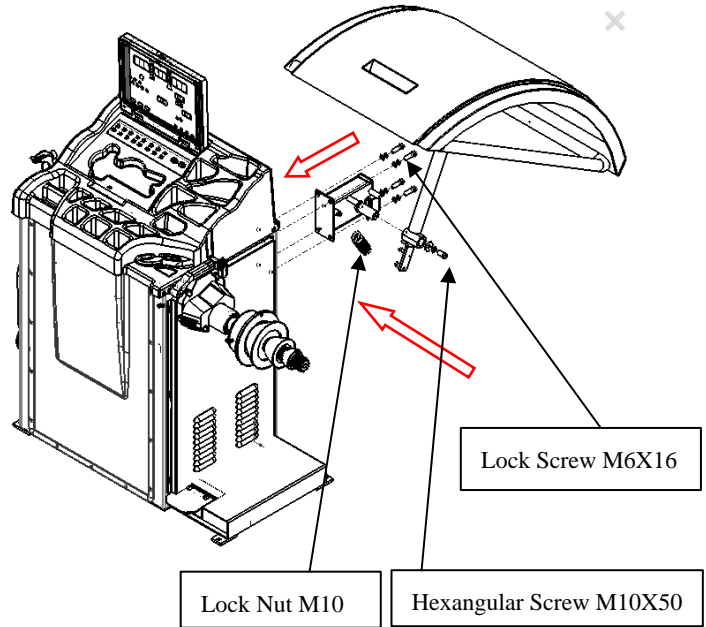

As the figure above, as the direction in the figure, insert into the protective hood supporting pipe and insert the socket head screw M10X50. And then lock the locknut along the reverse direction and loose the 2 hexagon nut to tight the socket head screw., This can prevent the protective hood from shaking to influence the test.

#### 2.2 MAIN SHAFT INSTALLATION

MAINSHAFT INSTALLATION: Before installation, use the ethyl alcohol and compressed air to clean up the center hole of the shaft and connect part. Use spanner and screw to fix the thread shaft on the balance shaft (Fig2)

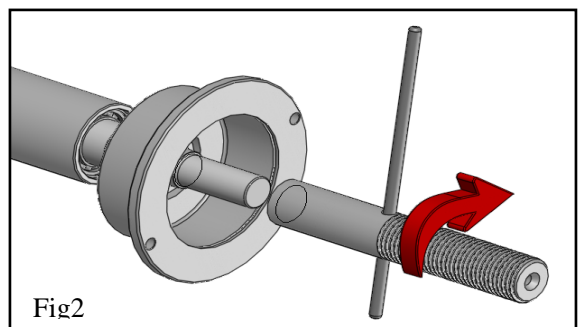

**2.3 EQUIPPED WITH POWER SUPPLY**

**ATTENTION!** According to the label on the connect between power cable and body, the power cable connect socket must be grounded with the reliable earth wire.

All the electrical devices installation must be done by the qualified staff. Before installation, please check If the power system is comply with the technical parameter marked on the nameplate of the machine.

The wiring of the machine must have the fuse and the perfect ground protection. And install the electrical Leakage automatic controls switch in the power source. And recommend the application of the stabilizer if the voltage of installation site is unstable.



Any electrical connect in the workshop is only done by the qualified technical staffs and it should meet the enforced regulation. Any electrical connect must be according to the following:

- Power on the data plate on the machine;
- Voltage decrease can not exceed 4% of the rated voltage on the data plate when full load (10% when start)
- Operators must:
  - Install the plug;
  - install 30ma circuit breaker;
  - install power cable fuse;
  - provide with effective workshop electrical connect to ground;
- prevent the authorized operation and pull out the plug to prolong the working life when not use the machine.
- if the machine directly connected to the power source through the power board not the plug, we should use the qualified staffs to operate.



Perfect ground is necessary for the correct operation. Do not connect the machine with air pipe, water pipe ,telephone line and the other unsuitable objects.

**III CB956 WHEEL BALANCER**

**TECHNICAL CHARACTERISTIC**

**3.1 CHARACTERISTIC:**

- adopts quality computer with the feature of high intelligence and high stable
- mechanical main shaft adopts high precision bearing driven, wear-resistant, low noise
- press stop key to realize the emergency stop
- full automatic dynamic/static balance check
- balance 3 ALU rim and 1 motorcycle tire
- self-calibration and full automatic trouble diagnosis

**3.2 MAIN TECHNICAL SPECIFICATION**

- rated voltage 230V 60HZ
- power 250W
- speed 7S (when wheel is about 20Kg)
- accuracy 1g
- noise ≤69dB
- rim diameter 10"~30"
- maximum wheel weight 159kg
- rim width 1.5~20"
- net weight 139 kg
- max wheel diameter 47inch
- working environment: temperature 0°C-50°C, RH: 30% —80% (no condense);

**3.3 WORK PRINCIPLE**

The micro CPU will provide the normal information if it checks each unit in the normal situation. And the operators can execute the balance operation. When balancing, MCPU can control the rotation of the balancer tester main shaft through the drive interface. The unbalance signal sensed by balance sensor is sent to the micro-processor port through A/D converter. CPU will integrated analyze the unbalance signal and angle signal to calculate the unbalance value and display the value through the LED. We can realize the man-machine talk through keyboard and LED.

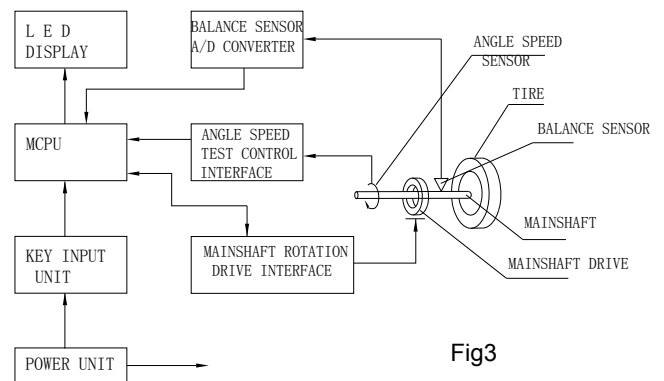

Fig3

FIG 3 CB956 WHEEL BALANCER WORK PRINCIPLE

## IV. TRANSPORTATION &

### INSTALLATION

#### 4.1 TRANSPORTATION

—Place, carry and store the machine according to the indication of the label on the package carton.

— Store environment: RH20%-95%  
temperature-10°C-+60°C

—When transport and use the machine, do not pull the rotation shaft, or it will cause the permanent damage.

4.1.1 After being sure that the package of your machine is perfect, you can carry the wheel balancer to the installation site.(Fig4). The choice of the installation should comply with the following requirements. The ambient temperature is 0°C-50°C and the RH ≤85%. And the installation site as shown in Fig5.

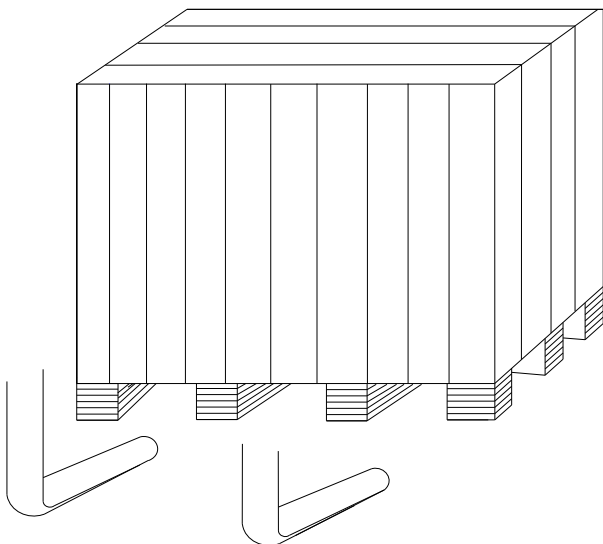

Fig 4

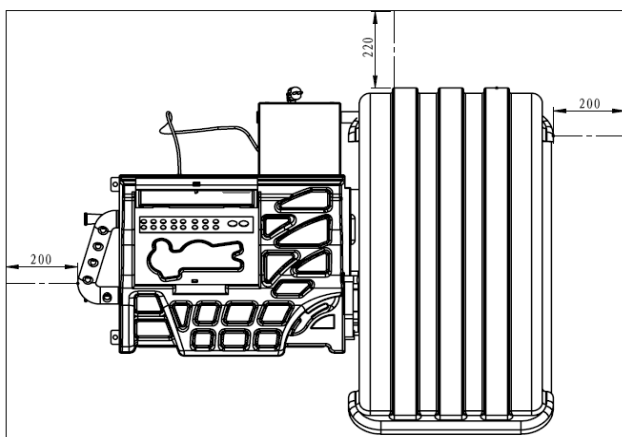

Fig5

4.1.2 Remove the upper cover of the package carton and check and confirm the wheel balancer, spare parts and documents you purchased according to the packing list. If you have any question, please contact with the dealer.

Package materials such as plastic, PBV, nail, screw, timber and carton must be placed into a scrap bin to treat according to the local regulation.

#### 4.2 INSTALLATION

Remove the connect bolt. And carry down the wheel balancer to place it on the flat and solid floor. We should store it indoor to avoid it from being exposed to the sunlight for long time and the moisture.

## V. SAFETY AND PREVENTION

5.1.1 Before operation, please confirm that you have read the entire warning label and the instruction manual. Not according with the safety instruction can cause the injuries to the operators & bystanders.

5.1.2 Keep your hands and the other parts of your body from the location with the potential danger. Before starting the machine, you must check it there existing the damaged part. If any break or damage, the machine will not be used.

5.1.3 In emergency situation, if the tire not fixed, you should press “STOP” to stop the rotation of the wheels. Adopts high strength protective cover to prevent the tire from flying in any direction and can only fall on the ground to protect the safety of the operators.

5.1.4 Before balancing, operators should check all the tires and wheels to find the possible faults. Do not balance the tires and wheels with fault.

5.1.5 Do not exceed the load capability of the wheel balancer and do not attempt to balance the wheel bigger than the designed dimension.

5.1.6 Wear suitable clothing such as suitable safety suit such as glove, glasses and working suit. Not wear



necktie, long hair, loose clothing. When operation the machine, the operators should stand beside the machine. Keep from the unauthorized personnel.

5.1.7 Before balancing, you must confirm the installation of the wheel suitable. Before rotation, be sure the nut turn 4turns around the thread shaft and firmly locked on the main shaft.

**GENERAL CONDITIONS OF USE**

The wheel balancers described in this manual must be used exclusively to measure the extent and position of car wheel unbalances, within the limits specified in the technical data section. Furthermore, models equipped with motors must be provided with a suitable guard.

**WARNING** Any use other than those described in this manual is to be considered improper and unreasonable.

**CAUTION** Do not start the machine without the wheel locking equipment.

**WARNING** Protective cover plays the role of prevention and safety.

**CAUTION** Do not clean or wash the wheels mounted on the machine with compressed air or jets of water.

**WARNING** Get to know your machine. The best way to prevent accidents and obtain top performance from the machine is to ensure that all operators know how the machine works.

**WARNING** Learn the function and location of all the controls.

**WARNING** Carefully check that all controls on the machine are working properly.

**WARNING** The machine must be installed properly, operated correctly & serviced regularly in order to prevent accidents & injuries.

**NAMEPLATE**

	Yingkou Guangming Instrument Factory No. 23, Hetuo Li, Jiao Feng Street, Zhaoliang District Yingkou, Liaoning 115001, P. R. China		
Model:	CB958B	Serial No.:	CE9588091601
Voltage:	230V~	Frequency:	50Hz
Phase:	1PH	Input Power:	0.3kw
Current:	4.0A	Weight:	125kg
Date of Manufacture:	2008-08-24		

Note: The following information coming from the nameplate. The nameplate is stuck in the center to the top on the rear of the machine. The meaning of each part is in the following:

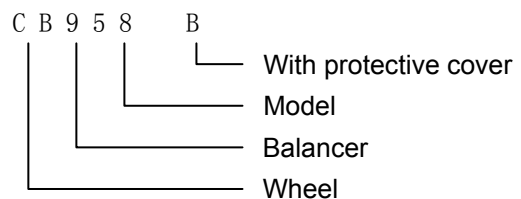

B、CE Mark This mark indicates that this model of machine has got the CE certificate

C、Series No The first 3 numbers is the abbreviate of the model. The middle 4 is the manufacture date and the last 4 is company product series number.

D、What on the cross line is the name and address of the company and under the cross line not includes the

above explained but the rated electrical parameters, such as voltage, frequency, power, phase number & full load current, and the weight and manufacture date of the machine.

## VI. CB956 CONFIGURATION & USE

### 6.1 CONFIGURATION

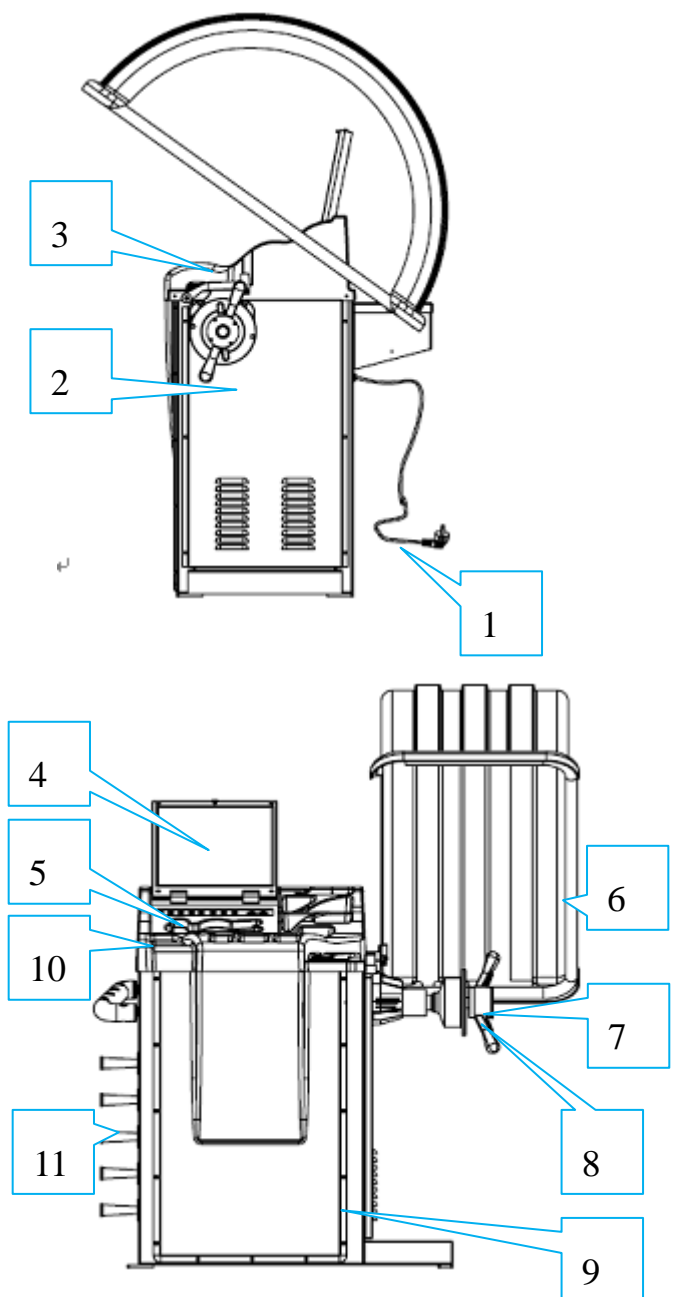

- 1. power plug    2 front panel    3.A sale
- 4. control panel    5. weight tray    6. protective cover
- 7. quick nut    8.balance shaft    9. body
- 10. power source switch    11. hinging handle

## 6.2 CB956 DISPLAY PANEL AND KEYBOARD PANEL

### 6.2.1 DISPLAY PANEL

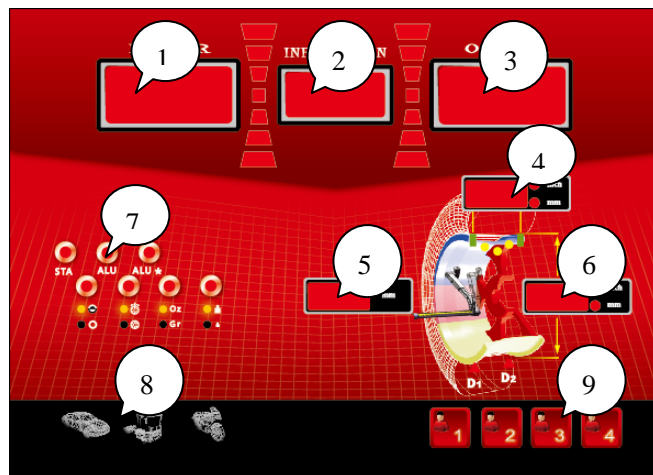

- 1- Inner unbalance display parameter display
- 2- information display
- 3- outer unbalance display parameter display
- 4- rim breadth display
- 5- Distance display
- 6- rim diameter display
- 7- balance mode display
- 8- Wheel mode selector
- 9- customer mode selector



In the condition of parameter input, this key is the distance between the wheel and balancer input key. When press the up/down key, you can input the distance from the rim to the machine. The default unit of the value is mm. When use the automatic scale to measure, you do not need to apply this key and the machine will automatically access the corresponding value of distance.



In the condition of parameter input, this key is the rim width input key. When press the up/down key, you can input the distance from the rim to the machine. The default unit of the value is inch. When use the automatic scale and automatic breadth scale to measure, you do not need to apply this key and the machine will automatically access the corresponding value of rim width.



In the condition of parameter input, this key is the rim diameter input key. When press the up/down key, you can input the rim diameter. The default unit of the value is inch. When use the automatic scale to measure, you do not need to apply this key and the machine will automatically access the corresponding value of rim diameter. After the setup of the factory setup, you can adjust to memory the current value.



**Static and dynamic balance mode conversion key**  
The default value when start up the machine, the default mode is the dynamic balance. If you want to execute the static balance, you can press this key.



**ALU balance mode** Press this key one time after another time, you can realize the selection on the ALU1\ALU2\ALU3 standard aluminum alloy mode.



**Self-definite the ALU mode** , Combine with the automatic scale can realize the stick of the weight.



**Weight split mode selective key** Can hide the weight after select the self-definite ALU mode. When the weight located behind the spoke, you can hide the weight behind the 2 spokes.



**Unbalance optimum** , Realize the optimum of the unbalance value of rim and tire.



MOT\CAR\BUS varies tire mode select according to the model of vehicle MOT application and the motorcycle tire balance CAR application on the common light wheel balance BUS application on the relative heavy wheel balance, features with speed reduction and high efficiency.



**Residual unbalance selective key** When press this key, you can display the residual unbalance value outer and inner of the tie.



**mm/inch selective key** When you input the width and diameter of the tire, you can use this button to realize the input of the different unit systems.



**Gr/Oz unit system conversion key** When not display the unbalance value, select this key to display the unbalance unit.



**1. Program entrance key** Select this key can enter the function of program setup.

**2. Confirm key** Confirm the input value.



Stop key



Start key

### 6.3 BASIC OPERATION

**6.3.1** Switch on the main switch on the left side of the machine, the display will display “888-708” and then “0”、“0” (it will display “0.00”, “0.00” in ounce state)

#### 6.3.2 MOUNT WHEEL

Preparation before test: Check and clean the dust and mud and if there are foreign bodies, such as metal and stone, clipped on the surface of the tire. And also check the air pressure of the tire is according with the specified value. Check if there are deformation on the rim positioning surface and installation hole. Check if there are any foreign bodies in the tire. Take off the original weight.

The installation methods of the wheel : positive positioning, negative positioning & flange disk positioning You can select different methods according to the practice.

##### 6.3.2.1 SMALL CAR WHEEL POSITIVE POSITION

Positive positioning is the normal method. It is featured with

simple and quick operation. It is mainly suitable to the common steel rim and aluminum alloy rim with small deformation.

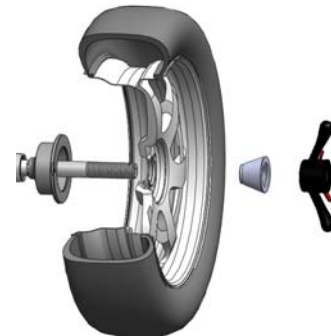

Main shaft → Wheel (direction of the rim installation surface is inside) → cone → quick nut

##### 6.3.2.2 SMALL CAR WHEEL NEGATIVE POSITION

When the deformation of the outside of the wheel, adopt this method to positioning to guarantee the accurate positioning of the steel rim inner hole and main shaft. It is suitable to the steel rim, especially the thick ALU rim.

The selection of the cone is relatively important: The dimension of the cone selected should fit the center hole of the rim. That means the diameter of the small and big end should be almost same to the center hole of the rim. This kind of position is easy to center.

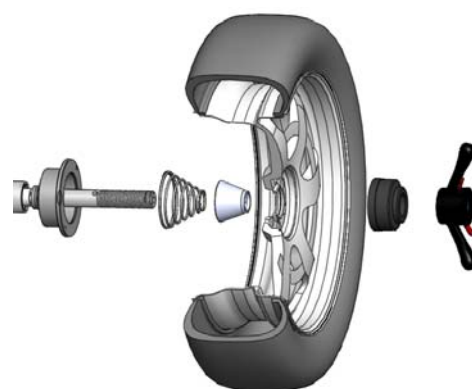

Main shaft → tower spring → suitable cone → wheel → bowl → quick nut

##### 6.3.2.3 FLANGE DISK POSITIONING (OPTIONAL)

Suitable to the big tire assemble

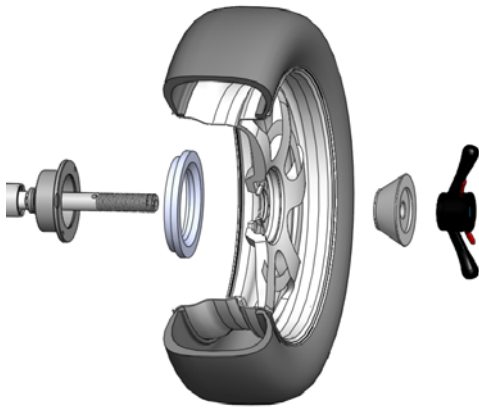

Main shaft → flange disk (fixed on the main shaft) → wheel → cone → quick nut

**Caution:** The choice on the cone should be adapted to the rim center hole and pay attention to its direction. Or it will cause the inaccurate measurement.

## 6.4 INPUT VALUE

### 6.4.1 Input Dis (Distance)



Pull the distance scale to the position to attach the weight and press the key to input the Di value into the display. At this moment, the display will display “Di”: “XXX” & we can also adjust this value by rotating the tire fixed on the main shaft.

When use the automatic scale, the machine will automatically access the distance from the tire to machine. To get the accurate precision, we had better execute a self-calibration.

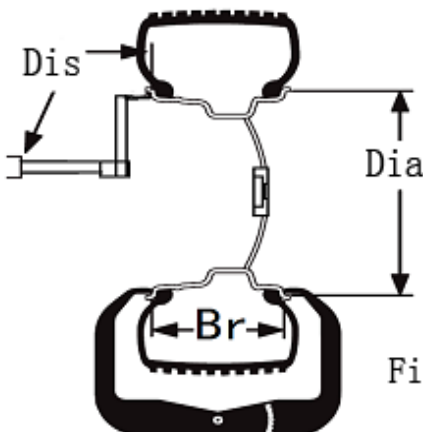

Fig 10

### 6.4.2 Input Br(Breadth) Value

Use the Br measurement caliper to measure the Br of the rim, press the key to input the Br value into the display. At this moment, the display will display “Br”: “XXX”, And we can also adjust this value by rotating the tire fixed on the main shaft. When use the Br measured scale, the machine will automatically access the sensed breath diameter, but must combined with the dis measurement scale.

### 6.4.3 Input the Tire Diameter Value ( Dia )

After confirming the rim diameter, press the key to input the rim diameter into the display. At this moment, the display will display “D”: “XXX”, And we can also adjust this value by rotating the tire fixed on the main shaft. When use the automatic scale, the machine will automatically access the sensed rim diameter.

### 6.4.4 UNIT CONVERSION:

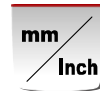

①The unit conversion of the Br of the rim from inch to mm:

Normally, the display of Br should be in inch. When you need the unit of the display to be mm, you can use the key to realize the unit conversion from inch to mm.

②The unit conversion of the D of the rim from inch to mm:

Normally, the display of D should be in inch. When you need the unit of the display to be mm, you can use the key to realize the unit conversion from inch to mm.

After unit conversion, the unit of the display values of rim Br and D are mm, but when you switch off and then on the wheel balancer, the unit will be still inch.



③The unit conversion from gram to ounce:

Normally, the unit of the unbalance value is gram (g). If

you want to make the ounce(Oz) to be the unit, you can execute the g/Oz conversion.

The unit of the displayed unbalance value is gram (g) . The way to realize the unit conversion from gram to ounce is to press the key.

**6.4.5** When press the start key  , the wheel balancer starts to run. A few seconds later, the machine automatically stops. The machine can also start by lowering down the protective cover which can be set by the program.

**6.4.6 DISPLAY UNBALANCE VALUE**

When the spin ends, the display will display the inner

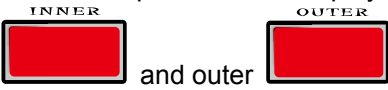
 and outer unbalance value of the rim. Use your hand to pull the wheel. When all the positioning lamps light inside and outside light, the weight adding position will be indicated.

**6.4.7** Rotate the wheel, when the left side positioning lamp all light, at this moment, the highest position is the inner unbalance position and when the right side positioning lamp all light, at this moment, the highest position is the outer unbalance position.

**6.4.8** Add the corresponding weight at the unbalance point and start test again until the balance of the tire.

**CAUTION**

1. When start the machine, use hand to pull the wheel to help it start rotation, especially to the relative bigger tire, to prolong the working life of the motor.
2. Check if there are any mistakes on the dimension.
3. Check if the balance methods meet the configuration of the rim and select the balancer most easily to balance.
4. Check if the contract nut tight or not.
5. When the balance ends, remove the tire. Pay attention to handle it with gentle and avoid knocking the main shaft. When clipping the weight. Use the hammer to clip the weight on the rim without too much

force. Do not knock the main shaft hardly to avoid damaging the sensor. The position to add the weight should be free from the grease and should be dry.

**6.5 RESIDUAL UNBALANCE VALUE DISPLAY**

The minimum value of the standard weight is 5g so if the weight you use is less than 5 g, the wheel balancer will not display the value and only displays the state of “00”. When you need to display the residual unbalance

value, you should press  and the display will immediately display the inside or outside unbalance value of less than 5g. The maximum residual unbalance value is 4 g.

**6.6 BALANCE MODE SELECT**

Select the balance mode according to the weight adding position and the balance mode. Press the

corresponding key  to select the balance mode. When you switch on the machine the machine will automatic enter into the dynamic balance mode and no need to select.

ATTENTION: The color of  stands for the weight attachment position after calibration.



dynamic—clip the weight on both side of rim (dynamic balance test once start )

static—use this mode when there are no weight on both sides



**static—optional for balancing the motorcycle** When balance the motorcycle ,

you need the special motorcycle adaptor accessory and with the assistance of the extension

scale to measure Di, Br and Di. Input the measure value into the Di, Br and Di display window. The input method is similar to the parameter input of the car..



**ALU1** — to balance the light aluminum alloy rim. Adopt clip the weight on the shoulders of the rim

$$Dis1 = Dis + \frac{3}{4}''$$

$$Br* = Br - 1 \frac{1}{2}''$$

$$Dia1 = Dia2 = Dia - 1''$$

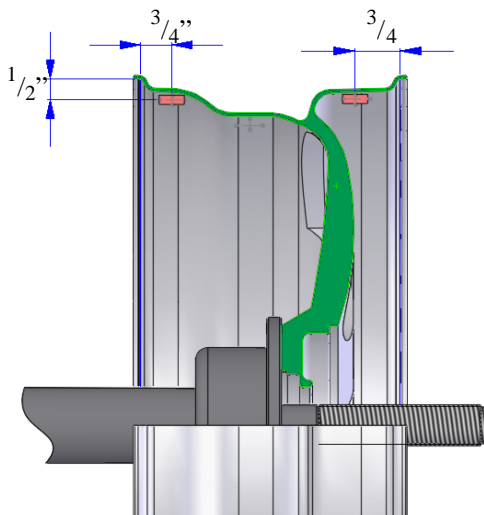

$$Dia1 = Dia - 1'' \quad Dia2 = Dia - 2 \frac{1}{2}''$$

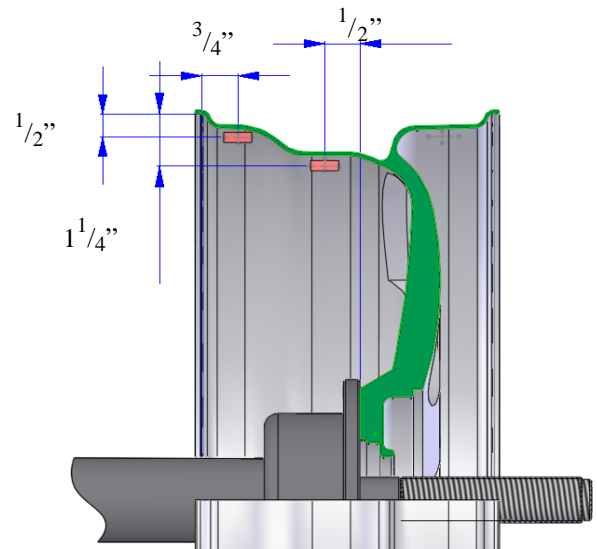

**ALU3** — clip weight inside and stick weight outside (outside position similar to ALU2)

$$Dis1 = Dis$$

$$Dis2 = 0 \text{ point to the Outer of the flange disk} - \frac{1}{2}''$$

$$Dia1 = Dia$$

$$Dia2 = Dia - 2 \frac{1}{2}''$$

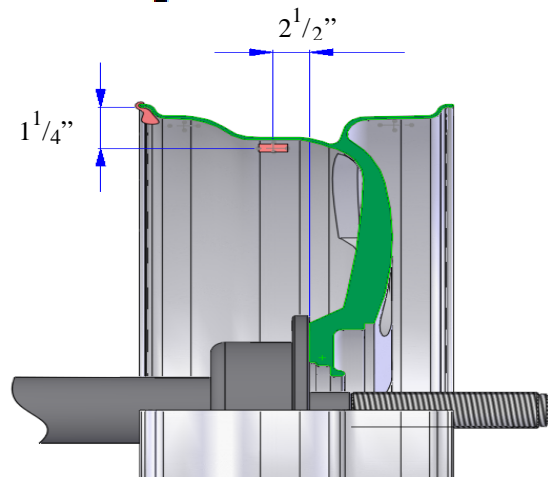

**ALU2** — for ALU rim, hidden weight

Inside

$$Dis1 = a + \frac{3}{4}''$$

$$Br* = 0 \text{ point to the Outer of the flange disk} - \frac{1}{2}''$$

$$-Dis$$



**ALU4**—clip weight inside and stick weight outside (outside position similar to ALU2)

$$Dis1=Dis$$

$$Dis2=Dis + \frac{3}{4}''$$

$$Dia1=Dia$$

$$Dia2=Dia-1''$$

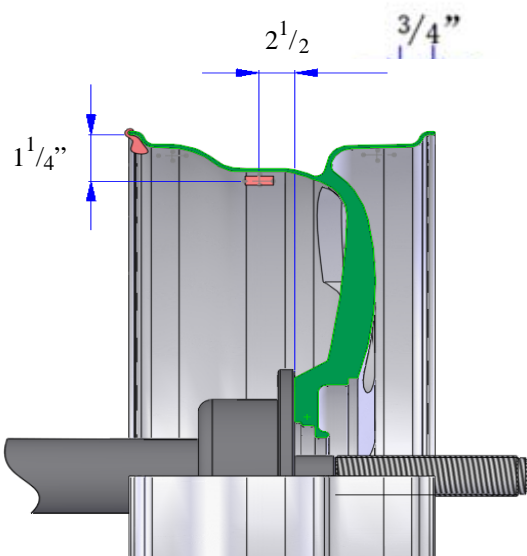

### 6.7 ALU\* SELF DEFINITION METHOD AND

#### WEIGHT HIDE FUNCTION



When the customer select the self definition ALU



modes, first use the scale to measure the inside position of the self-definition weight and then



hen press key to confirm. At this moment, the display will display the dimension at the D1 position. And then use the scale to measure the

inside position of the self-definition weight. When we hear the sound of tick, Meanwhile, the display will display the dimension at the D2 position. On this condition, we complete the measurement. Press start key to start up the machine. After the machine stops rotating, the display displays the inside and outside unbalance value. Rotate the wheel until the entire inside position indication lamps light up. At this moment, the D1 lamp will light. Step the brake to stop the tire. Pull out the scale and the Dis value will reduce when the length of the scale enlarged. When pull to the zero position, press the back end of the scale and the seal will mark a weight position. In a similar way, when the entire outer indication lamp light, mark a weight stick position and stick the corresponding weight and rotate the wheel to test and the self-definition ALU mode complete.



#### ALU SELF-DEFINATION BALANCE

MODE : You can hide the weight behind the spoke. This is only applied to the outside weight.

The detailed operation step is :

6.7. 1. After complete the self-definition ALU mode,



first stick the weight inside and select key.

The display will display “SP” –“5”. According to the



actual spoke quantity, press to adjust to the actual quantity of the spoke to clip the weight and



then press to confirm.

6.7. 2 Position any bar of the spoke to the 12clock



and hold on and press to confirm.

6.7. 3 COMPLETE THE SPLIT WEIGHT: Rotate the tire, the outside indication lamp will Rotate the tire and the outside indication lamp will help to split into two unbalance value at the 2 rims adjacent to the weight position. Adjust the position until the entire



indication lamps light up. At this moment, stick the weight of unbalance on the inner wall of the rim. That position must be the rear side of the 2 adjacent spokes.

## 6.8 OPT MODE

6.8.1 After complete the dynamic balance mode, press



. If exceed the setup value of the unbalance, it

will display "YES"-“OPT”, press  once again, it will display OPT1 OPT. At this moment, position the inflation nozzle at the 12clock. At the same time, use the chalk to draw a jump line at the rim and spoke.

Press  to confirm.

6.8.2 The display displays OPT2 OPT, use the tire changer to demount the tire and then mount the tire onto the main shaft of the wheel balancer and position the nozzle mark at 12 clock and start the machine.

6.8.3 Rotate the wheel until the entire indicating lamp light up, use the chalk to draw a line on the rim at 12clock and then use tire changer to coincide the 2above mentioned marking lines on the rim and the tire. At this moment, you complete the OPT operation.

## 6.9 CUYSTOMER MODE

The customer mode allows the user save the maximum of 4 customer-save modes.

6.9.1 First press  and hold on, you will enter into the customer mode select window after 5seconds.

Press   to select the customer and

confirm a special customer and then press  to

save.

6.9.2 Then you can adjust the habitual customer mode setup including if the protection cover function used or not, the on/off of the scale function, unit setup and tire parameter. After you complete the setup, you can

press and hold on the  and press  to save. The customer mode save is completed.

6.9.3 When you need to switch the customer mode, you can select according to 6.9.1. That means you can enter into the customer mode you select. That customer mode will be automatically the default mode after you start up.

## 6.10 SUPPLEMENTARY EXPLANATION:

Once switching on, you will see standard dynamic balance mode setup by the computer. When selecting ALU mode and the configuration of the aluminum alloy rim is similar to the above standard ALU1\ALU2\ALU3, you can get relative accurate balance effect. If the section of the tire similar to the one given be the program, you need do some adjustment on the position and weight of the weight. General speaking, 1~2 times of adjustment can reach relative satisfactory balance effect.



## 7 PROGRAM SETUP

### 7.1 PROGRAM FUNCTION INTRODUCTION

Press program key  to enter the program setup menu.

7.1.1 SET -OPT- (unbalance value optimum

calibration) : Press  key to confirm the



entrance. Select   up and down key to adjust the unbalance thresed value. You can

choose from 5Gr-100Gr and press  key to

confirm when you choose the corresponding value..

Press  key to enter the next function setup level.

7.1.2 **SET -p- (protective hood setup)** Once again

press  to confirm the entrance. Select 

 up/down key to ON/OFF setup the protective

hood function and then press  key to return.

7.1.3 **SET-SP- ( protective hood control )**

Select   to enter and then press

 key

To confirm the entrance and the setup is similar to the above.

7.1.4 **SET-CAR-APP( light tire minimum unbalance setup)** You can setup 1Gr and 5Gr. The setup is similar to the above.

7.1.5 **SET-BUS-APP(heavy tire minimum unbalance setup)** You can setup 10Gr and 50Gr. The setup is similar to the above.

7.1.6 **SET-BIP (beeper setup)** You can setup the on/off of the beeper.

7.1.7 **SET-RU1 (set up if the automatic scale Dis -to the machine- input automatic or not)** You can choose on or off.

7.1.8 After complete the above setup, press  to set to save.

7.1.9 **SET UP ( enter the next menu of the program)**

Involve the test on the various sensors and scales and the self-calibration.

7.1.10 **SET- UP** Press  key to enter into the special function setup.

**TES -INT- (sensor\scale measurement)** It can separately measure the photocell sensor, piezoelectric sensor, Dis, Bre and Dis . Through the test, we can identify the problem.

Press  key to enter and the display will display

TES POS (phase sensor). Rotate the tire forward and backward and the display will display TES -POS- XXX.

If rotate the tire backward, the value of XXX will increase and if forward, XXX will decrease.

Once again press key  to enter TES STA (dynamic test sensor). When service, press the sensor vertical to the main shaft.

You can execute the following step by step:

TES DYN( dynamic sensor test)

TES Dis (test for the distance to the machine )

TES Dia (test for the rim diameter)

By testing the above sensors, you can quickly find the trouble shooting point.

After entering into SET UP, if do not enter the TES- INT

program. Press  key, you can enter the customer weight marking (CAL WEI) You can select this function when you consider the test result inaccurate or the machine not used for a long time. When you enter into this function, display will display ADD -O- and press

 to start the machine for a time.



(This operation must be executed after mounting the tire or rim with the relative small unbalance value and input the correct value of the Dis, Bre and Dia) Or you will cause the inaccurate measurement result.

When rotate the wheel to test, it will display ADD -100. Rotate the wheel and clip a piece of standard weight of 100Gr at the top center position when the entire tire unbalance indicating lamp light. And start the machine once again, you can realize the self-calibration. This operation can make the machine fast restore its use of precision.

\*\*\*\*The shortcuts is located in the operation window not the program setup window. Press and hold on



key. Five seconds later, the program will automatically enter the self-calibration program and the display will display ADD -0- The other operation steps are similar to the above.

If need to enter the scale self-calibration, follow the following steps:



The display will display CAL WEI. Press key to enter CAL RL1

I Enter the scale calibration program : CAL RUL



(distance to the machine) Press key to confirm the entrance and the display will display Dis 0



Position the scale to the zero position, press key to confirm and the display will display Dia 14. Mount a medium size tire or rim on the main shaft and then, according to the diameter of the rim and tire mounted



on the shaft, press key to adjust the 14to the dimension of the rim mounted (change the value on the right window from 14 to 16 if the diameter of the tire mounted is 16”) and then pull out the scale end to lean it against the edge of the rim and at the same time



press key to confirm. Thus we have completed the automatic scale calibration.

II \*\*\*\*The shortcuts is located in the operation window not the program setup window. Press and hold on



key. Five seconds later, the program will automatically enter the self-calibration program and the



display will display ADD -0-. Then press key and the display will display “CAL”—“RUL”, The other operation steps are similar to the above.

The above operation step vector diagram is as follows:

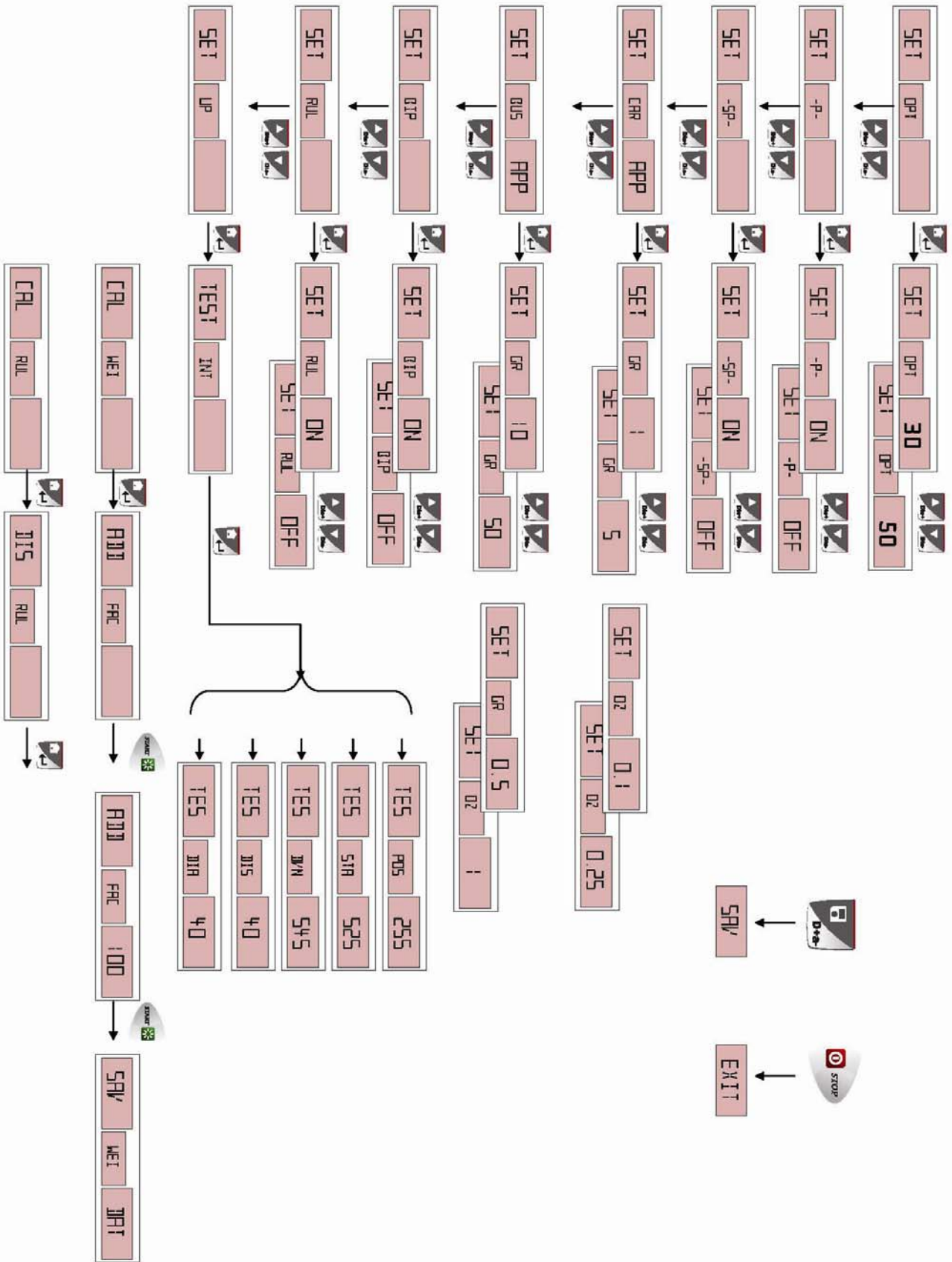

## 7.2 ERROR REMINDING:

If you can not solve the problems by the above methods, you can directly contact the professional persons.

DISPLAY	REASON	SOLUTION
ERR OPN	protective hood not lower	Lower down protective hood.
ERR SP	rotation speed not enough	Check belt and motr.
ERR OFF	stop error	Press the start key or raise the protective hood.
ERR FAC	factory setup error	Correctly execute the factory setup.
ERR USR	customer setup error	Execute the customer setup.

**Attention:** When change the computer board, the phase sensor or the press sensor, you must execute the self-calibration. When change the computer board, you should setup the parameter according to the parameter marked in the machine or on the original computer board. Repeat the self-calibration after the modification.

## 7.3 INSTALLATION AND WIRING OF THE PRESS SENSOR

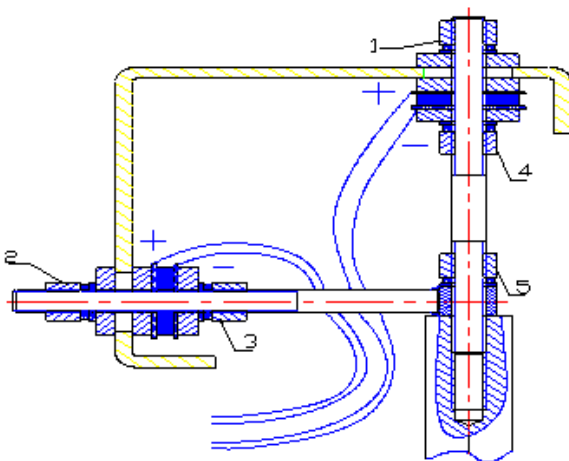

Sometimes, inaccurate balance or incorrect position is caused by the breakage of the press sensor. The changing method of the sensor is as following:

(1) Remove the upper cover and the right side panel of

the balancer.

(2) Detach the nut1 and 2, elastic washer, plain washer and large flat washer.

(3) Loose the back nut3.4.5 to detach every parts.

(4) Change the new sensors and tight the dual-head screw and then tight nut 5. The installation of the negative and positive pole of the piezoelectric ceramics disk of the sensor must follow the picture.

(5) Use the spanner to tight the nut4 and then nut 3. At this moment, you should pay attention to the horizontal and vertical sensor screws should be vertical. And the end of the screws should be just fallen into the 2 holes.

(6) Mount the nut1 and 2, elastic washer, plain washer and large flat washer and completely tight them. Usually, lock nut 1 and then nut 2. We require to flat the elastic washer and then return the nut 1/4—1/2turn. Use this way to get the normal pre-pressure of the press sensor (use torque wrench to lock and the torque is 40NM)

(7) There are glass glue coat on the surface of the press sensor and the normal installation result of the piezoelectric ceramics disk of the sensor is the IR should be larger than 50MΩ.

(8) Discharge the output line of the shortcuts press sensor, insert into the computer board after discharge to avoid the breakage of the computer board.

(9) Insert the vertical (⊥) & horizontal (//) sensor plugs according to the original position.

(10) Calibrate the balancer again and install the upper cover and the side panel after check result is normal.

## 7.4 GENERAL TROUBLESHOOTING & SOLUTION:

Description	Cause	Solution
Start the machine but not display.	<ol style="list-style-type: none"> <li>1. Check the circuit of 220V is normal or not.</li> <li>2. power board fault</li> <li>3. The cable between the power board &amp; computer loose</li> <li>4. computer board fault</li> </ol>	<ol style="list-style-type: none"> <li>1. Check &amp; connect the external power source.</li> <li>2. Changer the power board</li> <li>3. Check the plug cable</li> <li>4. Change the computer board</li> </ol>
Display is normal but the start button and input push button not working.	<ol style="list-style-type: none"> <li>1. contact switch not good</li> <li>2. machine breakdown</li> </ol>	<ol style="list-style-type: none"> <li>1. Open the housing of the machine and plug in and tight the contact switch plug.</li> <li>2. Start the machine again</li> </ol>
Display is normal but not braking after start.	<ol style="list-style-type: none"> <li>1. The cable between the power board and computer loose</li> <li>2. power board fault</li> <li>3. computer board fault</li> </ol>	<ol style="list-style-type: none"> <li>1. Plug in and tight the cable between the computer board and power board.</li> <li>2. Change the power board</li> <li>3. Change the computer board</li> </ol>
Balance is not accurate & difficult to reach "00"	<ol style="list-style-type: none"> <li>1. sensor lead connect or contact no good</li> <li>2. memory value lost</li> </ol>	<ol style="list-style-type: none"> <li>1. Connect again</li> <li>2. Correct the memory value according to the manual.</li> </ol>
Each spin, the change of the value will not exceed 5g.	<ol style="list-style-type: none"> <li>1. There are foreign body on the rim or the assemble surface in the rim center deformation</li> <li>2. sensor damp or quick nut not tightly clamped</li> <li>3. The external power voltage or the air pressure is not enough. The flange dick not locked.</li> </ol>	<ol style="list-style-type: none"> <li>1. Change the wheel</li> <li>2. Oven, recalibrate the sensor.</li> <li>3. Fix the anchor bolt.</li> </ol>
Each spin, the range of the change of value will be 20-90g.	<ol style="list-style-type: none"> <li>1. There are foreign bodies on the wheel or the unbalance of the wheel value too big.</li> <li>2. sensor damage</li> <li>3. external power source voltage too low</li> </ol>	<ol style="list-style-type: none"> <li>1. Change the wheel</li> <li>2. Check the sensor and wiring.</li> <li>3. Check power source and assemble stabilizer.</li> </ol>
Balance is not accurate & difficult to reach "00"	<ol style="list-style-type: none"> <li>1. Sensor damp or damage</li> <li>2. Program chore</li> </ol>	<ol style="list-style-type: none"> <li>1. Calibrate again, oven and then self-calibration or change.</li> <li>2. Self-calibration again</li> </ol>
When second mount & demount, the error will exceed 10g.	<ol style="list-style-type: none"> <li>1. Wheel internal hole irregular</li> <li>2. Flange disk assemble not properly</li> </ol>	<ol style="list-style-type: none"> <li>1. Change the wheel</li> <li>2. Check the assemble surface and try again.</li> </ol>

## 7.5 STANDARD ACCESSORIES OF THE WHEEL BALANCER

### STANDARD ACCESSORIES OF THE WHEEL BALANCER

#### Standard Accessory



#### Optional Accessory

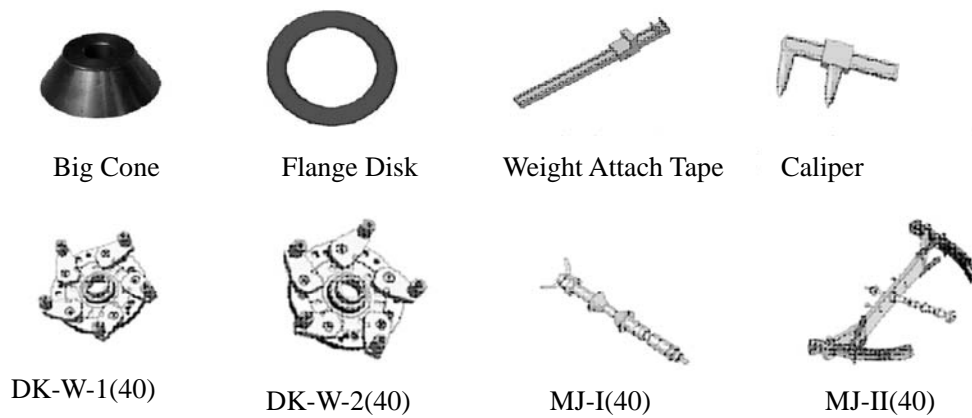

#### STANDARD ACCESSORY LIST OF THE WHEEL BALANCER

weight mount and demount pliers-----	1piece
Br measure scale -----	1piece
Centering cone-----	3pieces
Quick Nut-----	1piece
Thread Shaft-----	1piece
M10X160 socket head screw -----	1piece
Standard weight -----	1piece
Bowl -----	1piece
Bowl protective cover-----	1piece
Spring -----	1piece

## VIII MAINTENANCE



WARNING

The manufacturer declines all responsibility in the event of claims resulting from the use of non-original spare parts or accessories.



WARNING

Unplug the machine from the socket and make sure that all moving parts have been locked before performing any adjustment or maintenance operation.



WARNING

Do not remove or modify any part of the machine (except for service interventions).



CAUTION

Keep the work area clean.

Never use compressed air and/or jets of water to remove dirt or residues from the machine. Take all possible measures to prevent dust from building up or rising during cleaning operations. Keep the wheel balancer shaft, the securing ring nut, the centering cones and flange clean. These components can be cleaned using a brush previously dipped in environmentally friendly solvents. Handle cones and

flanges carefully so as to avoid accidental dropping and subsequent damage that would affect centring accuracy. After use, store cones and flanges in a place where they are suitably protected from dust and dirt. If necessary, use ethyl alcohol to clean the display panel. Perform the calibration procedure at least once every six months.

### USING THE GREASE

#### Greasing the wheel balancer

The only rotating parts of the wheel balancer are the motor and the balancing shaft, so the bearing of these components must be checked periodically by the operator and greased. If the machine is used frequently (more than two hours per day), check the bearing every year; if the machine is not used so often, the check can be made every two years. The bearing cannot be opened for the test, so insert a screwdriver and check the sound produced. As the bearing acts as a clamping support, it is not easy to change or take out the grease. In addition, the rotation speed is not high for the machine, so it is not necessary to change the grease. If you notice an incorrect working or a noisy bearing, replace the bearing. If the customer confirms that the bearing has not been replaced, just change the grease, then disassemble the bearing, open the dust guard ring and add the grease (XHP103), carrying out these operations under the guidance of a professional. Calibrate the machine after replacing the bearing. If the operation has not been carried out correctly, the machine precision will be affected, so reposition the dust guard ring, reassemble the machine and repeat the adjustment.

Technical safety card for using grease in the wheel balancer

Mobilgrease XHP  
NLGI degree  
Type of thickener  
Colour, appearance



Penetration on the processed item 25°, ASTM D 217, mm/10	235
Dropping point, °C, ASTM D 2265	280
Viscosity oil base, ASTM D 445, cSt @ 40°C	100
Change of penetration consistency, ASMT D 1831 (established upon the rolling of the greases), mm/10	10
4 spheres test, impression diam., ASTM D 2266, mm	0.5
4 spheres test, welding load, ASTM D 2509, kg	315
Test Timken OK load, ASTM D 2509, lb	
Stability of oxidisation bomb method, ASTM D 942, pressure drop at 100 hours, kPa	45 35
Corrosion prevention, ASTM D 1743	Passed
Emcor rust, IP 220, wash away with acid water	0
Rust protection, IP 220-mod, wash away with distilled water	0
Corrosion on copper, ASTM D 4048	1A
Resistance to water spray, ASTM D 4049, % spray	15
Wash away with water, ASMT D 1264, loss (weight%), @ 79 C	5

Thus, the hazardous consequences that non-specific treatments of the substances contained in these products, or improper use of parts of them, may have on the environment or on human health are prevented. Furthermore, this helps to recover, recycle and reuse many of the materials contained in these products.

Electrical and electronic manufacturers and distributors set up proper collection and treatment systems for these products for this purpose.

Contact your local distributor to obtain information on the collection procedures at the end of the life of your product.

When purchasing this product, your distributor will also inform you of the possibility to return another end-of-life piece of equipment free of charge as long as it is of equivalent type and had the same functions as the purchased product.

Any disposal of the product performed in a different way from that described above will be liable to the penalties provided for by the national regulations in force in the country where the product is disposed of.

Further measures for environmental protection are recommended: recycling of the internal and external packaging of the product and proper disposal of used batteries (only if contained in the product).

Your help is crucial to reduce the amount of natural resources used for manufacturing electrical and electronic equipment, minimize the use of landfill for product disposal and improve the quality of life, preventing potentially hazardous substances from being released in the environment.

### SCRAPPING

If the machine is to be scrapped, separate all electrical, electronic, plastic and ferrous components and dispose of them separately, as provided for by local regulations in force.

If the machines have the crossed-out bin symbol on



their data plate , the following disposal procedure must be applied to.

This product may contain substances that can be hazardous to the environment and to human health if it is not disposed of properly.

Electrical and electronic equipment must never be disposed of in the usual municipal waste but must be separately collected for their proper treatment.

The crossed-out bin symbol , placed on the product and on this page, reminds the user that the product must be disposed of properly at the end of its life.

### FIREFIGHTING MEANS TO BE USED

Consult the following table to choose the most suitable

fire extinguisher.

Dry materials

Water YES

Foam YES

Powder YES\*

CO2 YES\*

YES\* Use only if more appropriate extinguishers are not at hand or when the fire is small.

Flammable liquids

Water NO

Foam YES

Powder YES

CO2 YES

Electrical equipment

Water NO

Foam NO

Powder YES

CO2 YES



Warning

This table contains general instructions to be used as guidelines for users. All the applications of each type of extinguisher must be obtained from the relevant manufacturer.

#### TECHNICAL TERMS

The following is the description on some of the technical terms:

**BALANCE CYCLE** From the start to the end of the rotation of the tire, during this process the unbalance value has been calculated.

**CALIBRATION** See the self-calibration

**CENTERING** The process to mount the wheel on the balance shaft, in this process we should guarantee the rotation axis of the wheel should coincide to the balance shaft.

**CONE** It is a conical component with the centre hole, through which the balance can pass to find the center of gravity of the tire. The specification of the center of the cone is in the limit of the diameter of the center hole of the rim.

#### DYNAMIC BALANCE

the process to calibrate the unbalance of the tire by using 2 pieces of weight which must applied on the 2 sides of the tire

**FLANGE DISK (accessory)** mounted on the balancing shaft through he center hole to make the wheel perpendicular to the rotation axis to support and center the wheel

**BALANCER FLANGE** conical disk component used to make the wheel perpendicular to the rotation axis

**NUT** to fix the wheel on the balancer

#### SELF-CALIBRATION

the process in which we can calculate the suitable calibration coefficient and increase the accuracy by calibrate the error from some period of using the machine

**SENSOR(measurement arm)** a movable mechanical component which can measure the data of distance, diameter and breath .etc. when it contacts with a specific point of the rim and which can automatically measure if equipped with an suitable measurement converter

**ROTATION** the entire process from the start to the end of the rotation of the wheel

#### STATIC BALANCE

the process to calibrate the unbalance the tire by using a piece of weight which is usually in the center of the rim and the less breadth of the wheel, the more

accuracy

### THREAD SHAFT

It is thread part of the balance shaft to fix the wheel. This part is separately package to the machine when supplied to the customer.

**UNBALANCE** the uneven distribution of the wheel quantity, which can cause the centrifugal force in the process of the rotation of the wheel.

## IX.DETAILED INSTRUCTION ON THE OPERATION OF THE MACHINE:

### HOW TO BALANCE A TIRE

1. Switch the power supply.
2. Select the suitable cone according to the size of the tire and mount and fix the tire on the balance shaft and tightly lock it.
3. Input the tire parameter  
3.1 Pull out the balance scale to measure the dis(the distance from the inner of the tire to the machine body. According to the reading value(the unit

is cm), press  , to adjust the value to make the left window display the measurement value.

Note:The unit of the right window is mm. When select the automatic scale function, the mechinwillautomatically access the value. eg You should input 55mm, if the measured value is 5.5cm.

**3.2** Use the breath measurement scale to measure the

Bre(rim shoulder distance). Pres 

key and input Bre value, the default value of which is inch. If you want to change the unit to mm, press

 to realize the unit conversion of in/mm

a) Check the D value(rim diameter) indicated on the tire. Press the key to calibrate the value in the right window to make it to be the rim diameter and you can

convert it to be the unit of mm. Press  on the keyboard to realize the conversion of in/mm (When select the automatic scale function, the machine will automatically access this value) .

Lower down the protective hood and you can also start the mahine be use the option operation of pressing the start key. The machine will automatic break after the completin of the test. The corresponding values will display on the left/right wingdow. Rotate the tire and attach the weight at the top center inner/outer according to the displayed value when the entire position indication lamps light. Once again start the machine to test and the window will once again display the unbalance value. The wheel balance operation will be end when the displayed value is in the balance range you need. Usually 1 time of operation is enough to balance the tire and reach the satisfied balance effect.

Herewith, we do not want to detailed describe the ALU(aluminum alloy). You can operate the ALU1\ALU2\ALU3\ALU4 according to the drawing in the chapter 6.6.

OPT mode & ALU and OPT function (you will see the detailed demo CD.)

# APPENDIX 1

## LAYOUT OF THE POWER SUPPLY BOARD

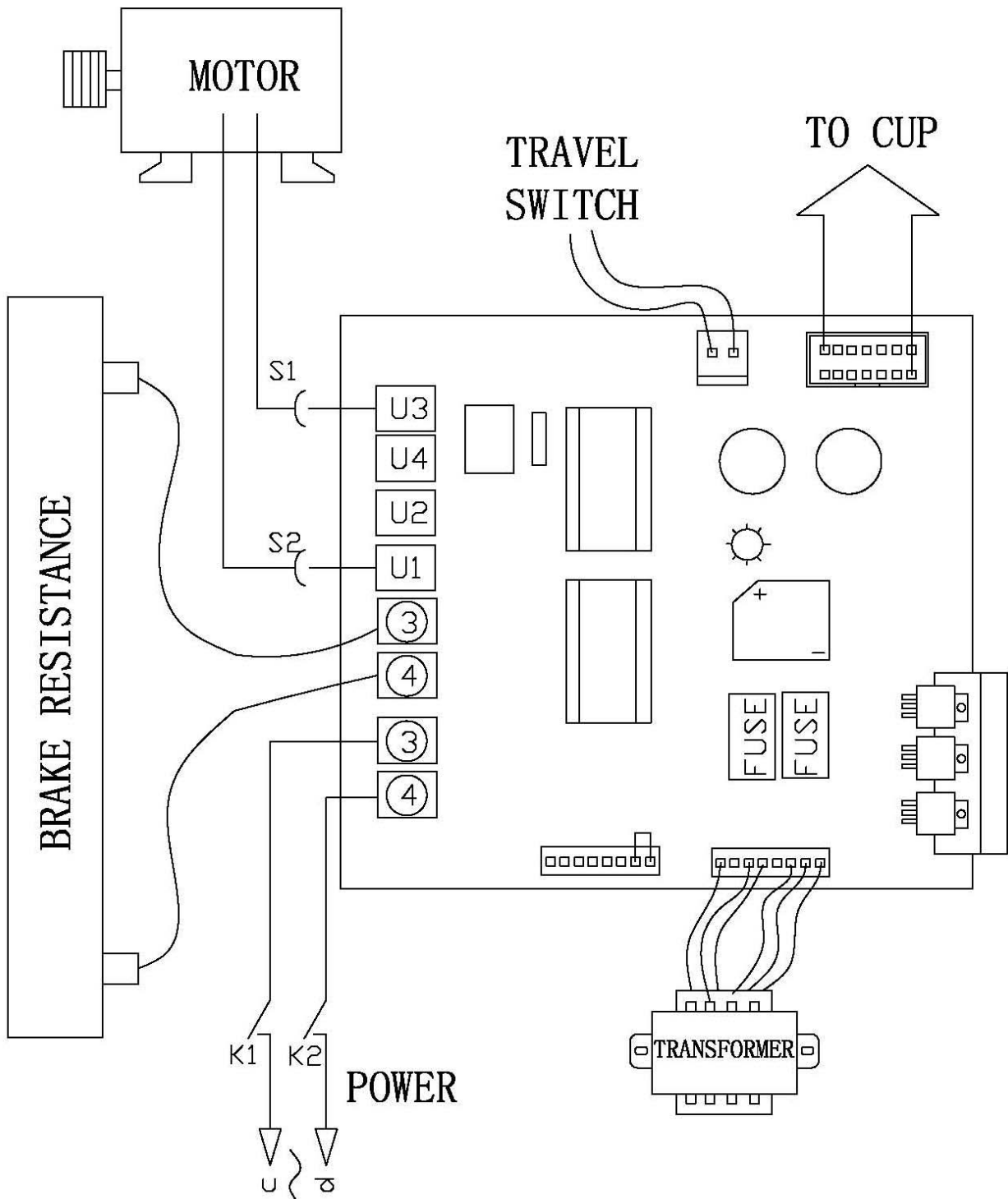

## APPENDIX 2

### WIRING DIAGRAM

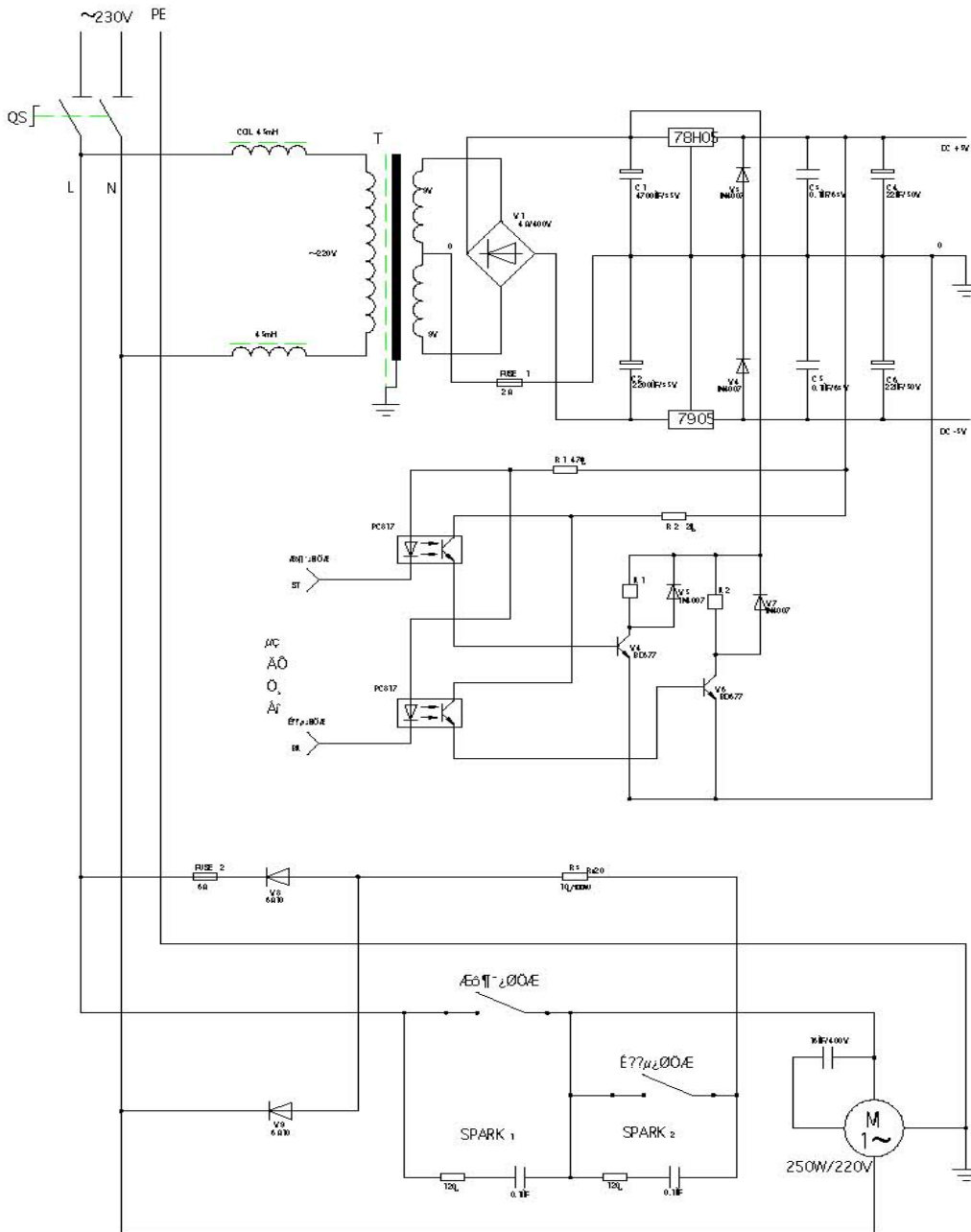

Sequence No:  
 Model:  
 Production Date:

### WARRANTY

Machine involves the warranty period of 90 days and the parts and components are 6 months. The manufacturer is only responsible for the normal wear, improper transportation or use and the maintenance without care. Manufacturer will not notify the customers when improve the products and production line for this warranty terms do not involve the change result. All the claims must clearly note the model and sequence number of the machine.